



Structural Solutions

Modal
Advanced Swept Sine

**User's
Manual**



MODAL 2
 Modal Installation guide6
 Modal User's manual22

ADVANCED SWEPT SINE 93
 Advanced Swept Sine Installation guide96
 Advanced Swept Sine User's manual 104

Modal

TABLE OF CONTENTS:

MODAL INSTALLATION GUIDE.....	6
First checking.....	8
Required Configuration.....	8
Recommended PC configuration:.....	8
Equipment required for the installation:.....	8
Installation	9
Installation of the Modal Solution	9
First steps	14
Modal first description	14
To know more	17
Upgrade procedure.....	18
Upgrades available	18
Upgrade procedure	18
Upgrade order	18
Software upgrade	18
Dongle upgrade	20
MODAL USER'S MANUAL	22
Introduction	23
Operating Deflection Shape	23
Experimental Modal Analysis	23
Operational Modal Analysis	24
Modal features	24
Environment.....	27
General interface	27
Geometry modelling	30
Principle.....	30
Coordinates	30
Global and local coordinates	30
Cartesian coordinate	30
Cylindrical coordinate.....	30
Spherical coordinate.....	31
Define a coordinate.....	31
Nodes.....	32
Define a node	32
Directions of a node	32
Links.....	33
Geometry in Modal	33
geometry modeling illustration	33
Basic geometry library	36
Local coordinate systems	36

Mesh type.....	36
1st ID	37
Properties	37
Interactive geometry modelling	42
Import geometry	45
Data acquisition.....	46
Test planning.....	47
Transducers definition	48
Measurement parameters setup	49
Display and save options	50
Analyzer connection.....	50
Acquisition control	50
Signal processing	52
Estimation	52
Detrending	53
Decimation	53
Setup of FFT.....	54
Windowing	55
Boxcar	55
Exponential.....	55
Force & Exponential	56
Hanning.....	56
Hamming	56
Flattop	56
ODS & Modal Analysis	58
Modal Analysis process illustration.....	58
Selecting an Algorithm.....	58
Doing Modal Identification.....	59
Operating the Results	61
Modal Indicator Function (MIF)	61
Operating Deflection Shape	62
Time domain ODS	62
Frequency Domain ODS.....	63
Modal Analysis	63
Modal identification methods	63
Narband (CMIF)	67
Selecting a Peak.....	67
Auto Identification.....	67
Checking curve fitting and Refitting	68
Selband SIMO (RFOP)	68
Input Number	69
Output Number	69
Denominator Order	70
Modal Order	70

Numerator Order	70
Selband MIMO1	70
Number of Bars	71
Order of System.....	71
EMA Selband MIMO2	71
Input Number	71
Output Number	71
Denominator Order	71
Modal Order	72
Numerator Order	72
EMA Broadband (BBFD)	72
Features/Advantages of EMA Broband	72
Main Procedures for EMA BroBand.....	72
On the Toolbar of "BBFD Setting" Diagram	78
Modal validation, MAC & COMAC	79
Import / Export.....	83
Import.....	83
Geometry.....	83
Data Files	83
UFF	83
OROS Format.....	85
Equations.....	86
Modes.....	87
Export	87
Data	87
Table	87
Graphics.....	88
Animations.....	88
Print	89
Shortcuts operation	90
Shortcut Operations in the Explorer	90
Shortcut Operations in the General Interface	90
Shortcut Operations in the 2D Curve Window.....	91
Shortcut Operations in the 3D Graphics Window.....	91
Shortcut Operations in the Dialog of 'Showed Series'	92

MODAL INSTALLATION GUIDE

Thank you for purchasing Modal software.

Modal is a dedicated tool for processing a comprehensive modal analysis.

Some tools are available to create your modal project from the beginning to the end.

Start with the construction of the geometry and the acquisition of data in an optimized window.

After these first steps, continue naturally by displaying very quickly Operating Deflection Shapes. Finally, with the powerful algorithms proposed, modal parameters: frequencies, damping, mode shapes can be easily obtained from either modal data or operating data.

This "**INSTALLATION GUIDE**" will help you to install and run the **Modal** software.

For getting detailed information on the software, you can go and visit the Online Help embedded within the software. For beginning to use your new modal software, you can follow the instructions in the 'Getting Started' document installed simultaneous to the software.

FIRST CHECKING

REQUIRED CONFIGURATION

RECOMMENDED PC CONFIGURATION:

Minimum	Pentium 4/ 2 GHz / 256 ¹ MB RAM with Windows XP or 512 ¹ MB with Windows Vista/ Graphics video adapter with at least 32 MB memory / 150 MB free on HD + storage for measurements and signals, 1024 x 768 display (XGA), DirectX 8.0
Recommended (for laptop)	Dual/quad core processor (ex: Intel Core i5) / > 2.5 GHz / 4 GB of RAM / Graphics video memory 1 GB / 1 GB free on HD + storage for signals / CD or DVD ROM drive / 1440 x 900 display / Windows 7 pro
Recommended (for desktop)	Quad core processor (ex: Intel Core i7) / 6 GB of RAM / Graphics video memory 1 GB / 1 GB free on HD + storage for signals / CD or DVD ROM drive / 1920 x 1080 display / Windows 7 pro
Connection	Type: Ethernet 100base TX , 100 Mbit/s - Connector: RJ45 For removable disk: USB 2.0 - At least one USB port for dongle key.
Operating systems	Windows XP Pro Service Pack 3, Windows Vista Business Service Pack 2, Windows 7 (recommended)

EQUIPMENT REQUIRED FOR THE INSTALLATION:

Software CD containing Modal and the online help.

A dongle dedicated to Modal software

INSTALLATION

INSTALLATION OF THE MODAL SOFTWARE

Insert the CDROM in the appropriate driver and wait for the Autorun program or run the "setup". The following window is displayed:



Click on "Next >".

The following window is displayed:

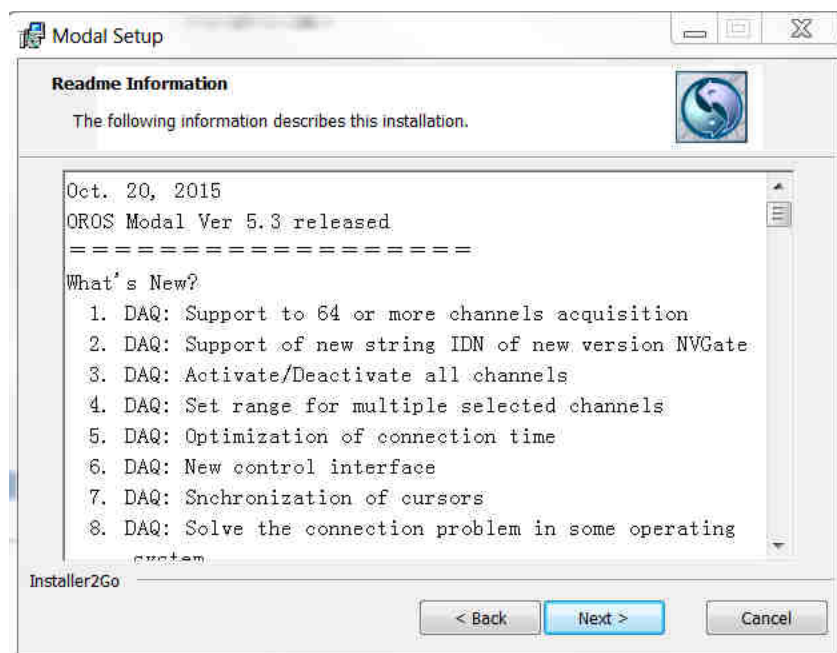

Read the terms in the license agreement and click on "Next >".

The following window is displayed:

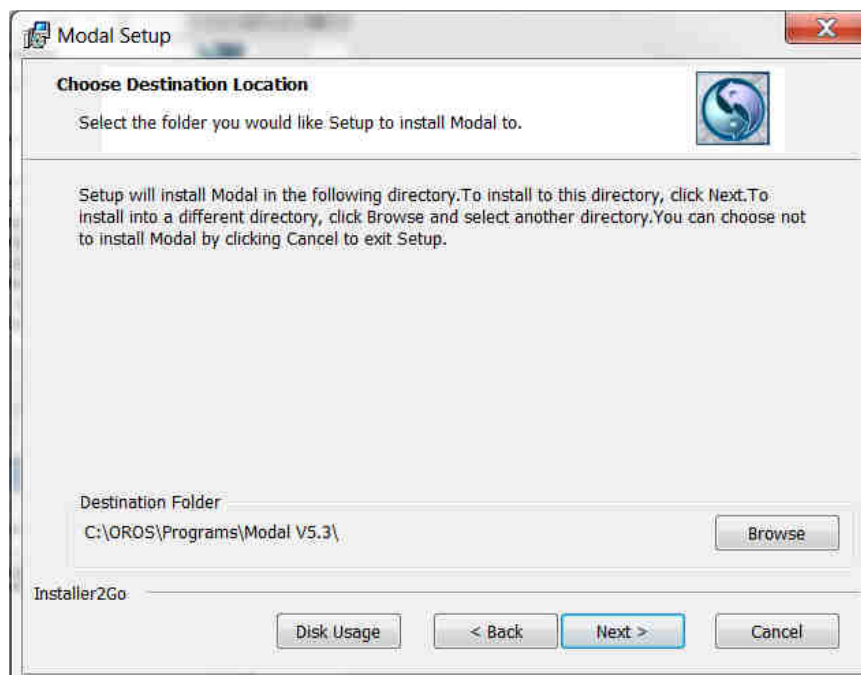

Select the location of the "Modal" folder. By default, Modal is installed in C:\Program Files\OROS\NVSolutions\Modal V5.2

Click on "Next >".

The following window is displayed:

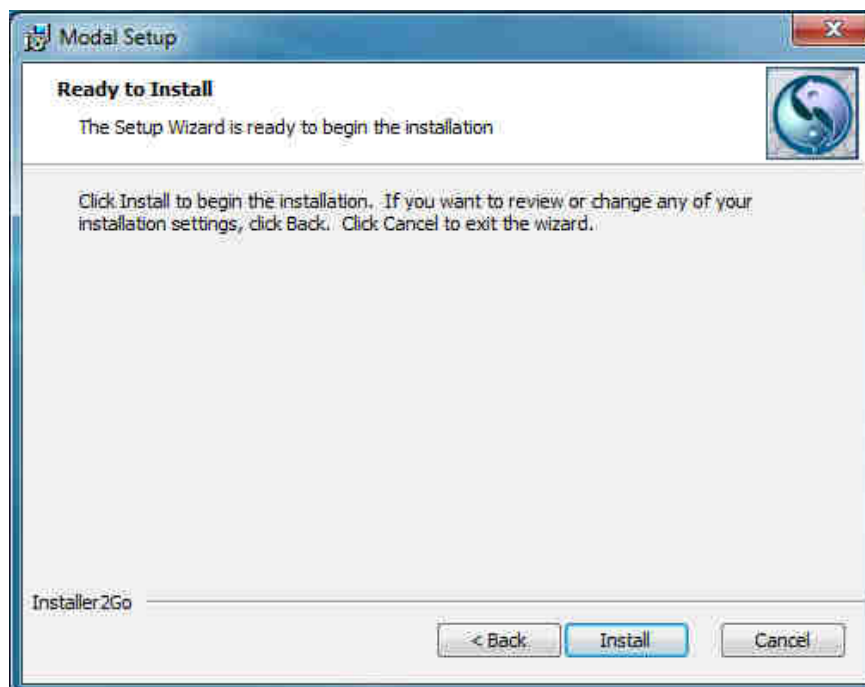

Click on "Install".

The following window is displayed:

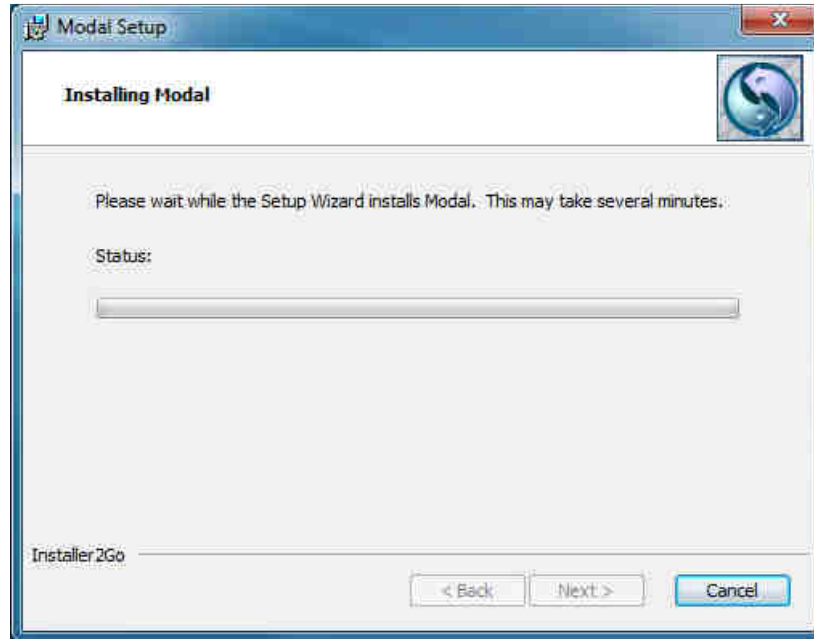

Wait while the Setup Wizard installs Modal.

Then the following window is automatically displayed.



Click on "Install Driver". The following window may be displayed.

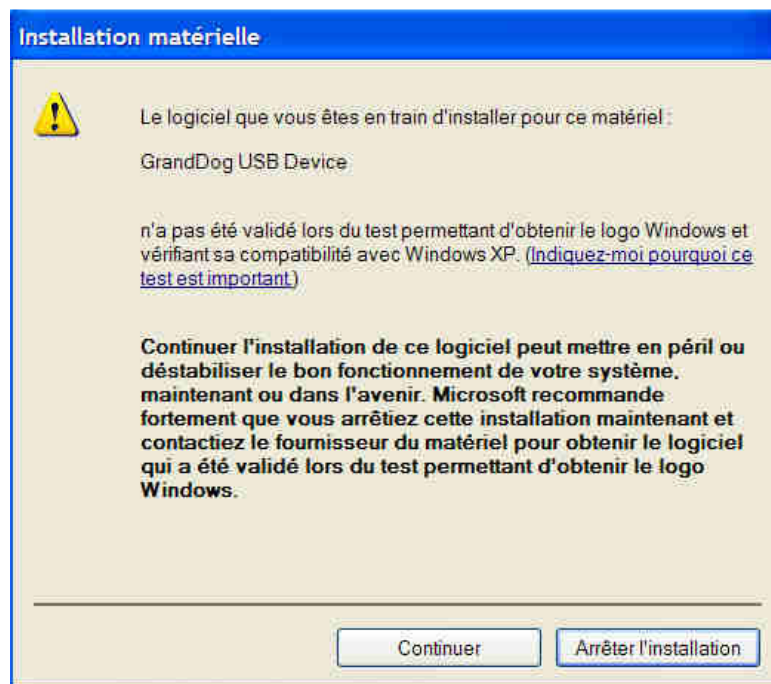

Click on "continue".



A message indicates if the driver has been installed successfully.

Click on "Close".

Then the following window is displayed.

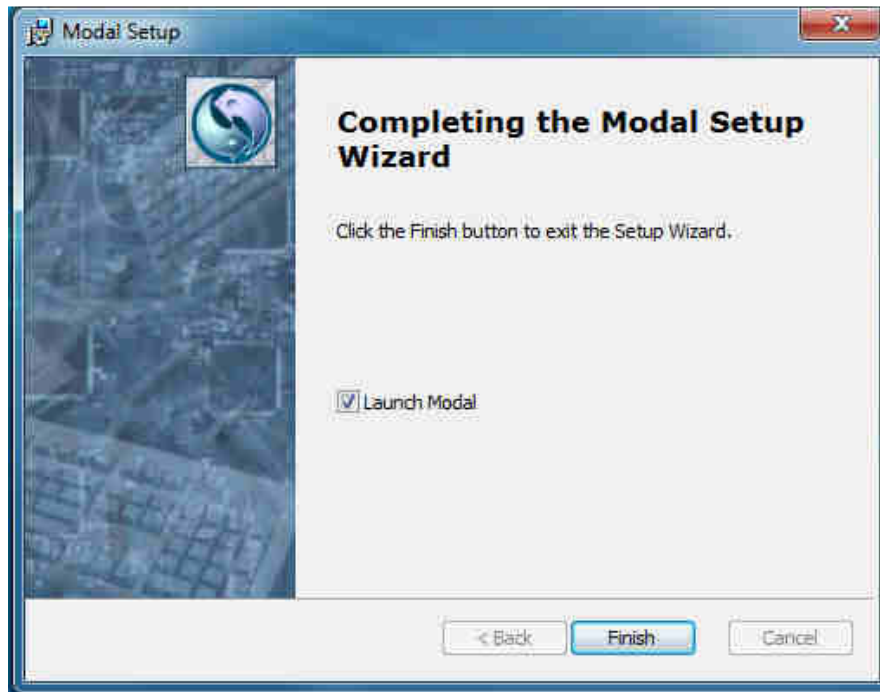

Pick "launch Modal" if you want to launch the software immediately.

Warning: Don't forget to plug the dongle to launch correctly the software

Click on "Finish".

FIRST STEPS

MODAL SOFTWARE FIRST DESCRIPTION

When you launch Modal, the following window appears few seconds.



Finally the following window is displayed

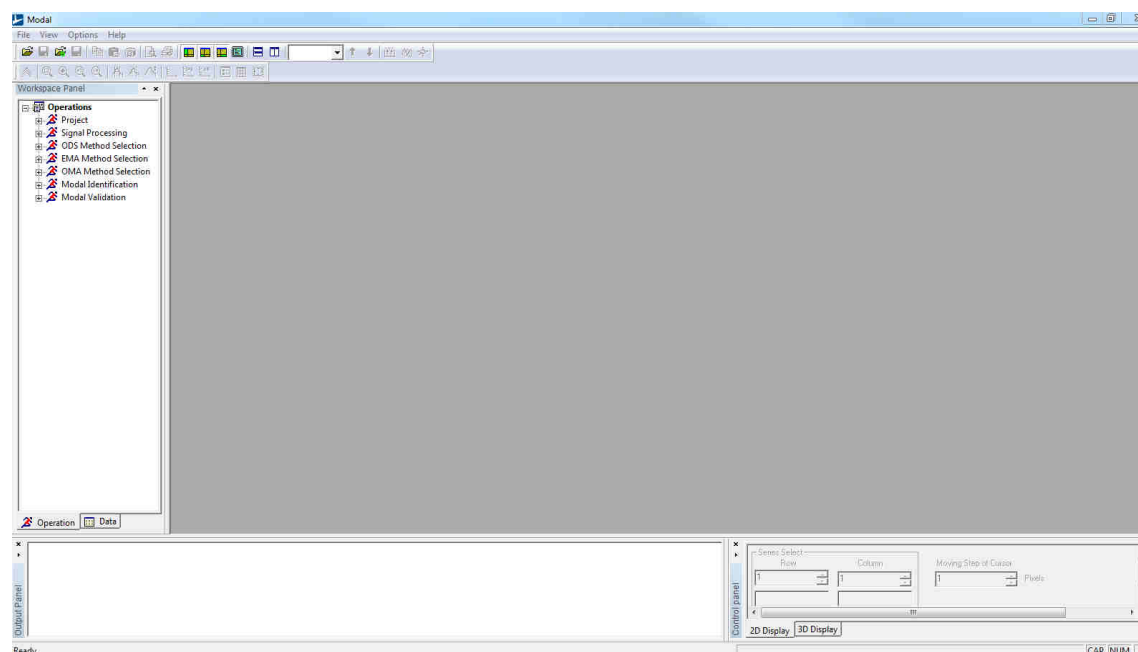

Click on 'file' in the menu toolbar and on 'open workspace'.

For the first time you can open one of existing projects installed at the same time than the software in the directory 'examples'.

There are:

- 4 different projects for Experimental Modal Analysis
- 2 different projects for Operational Modal Analysis

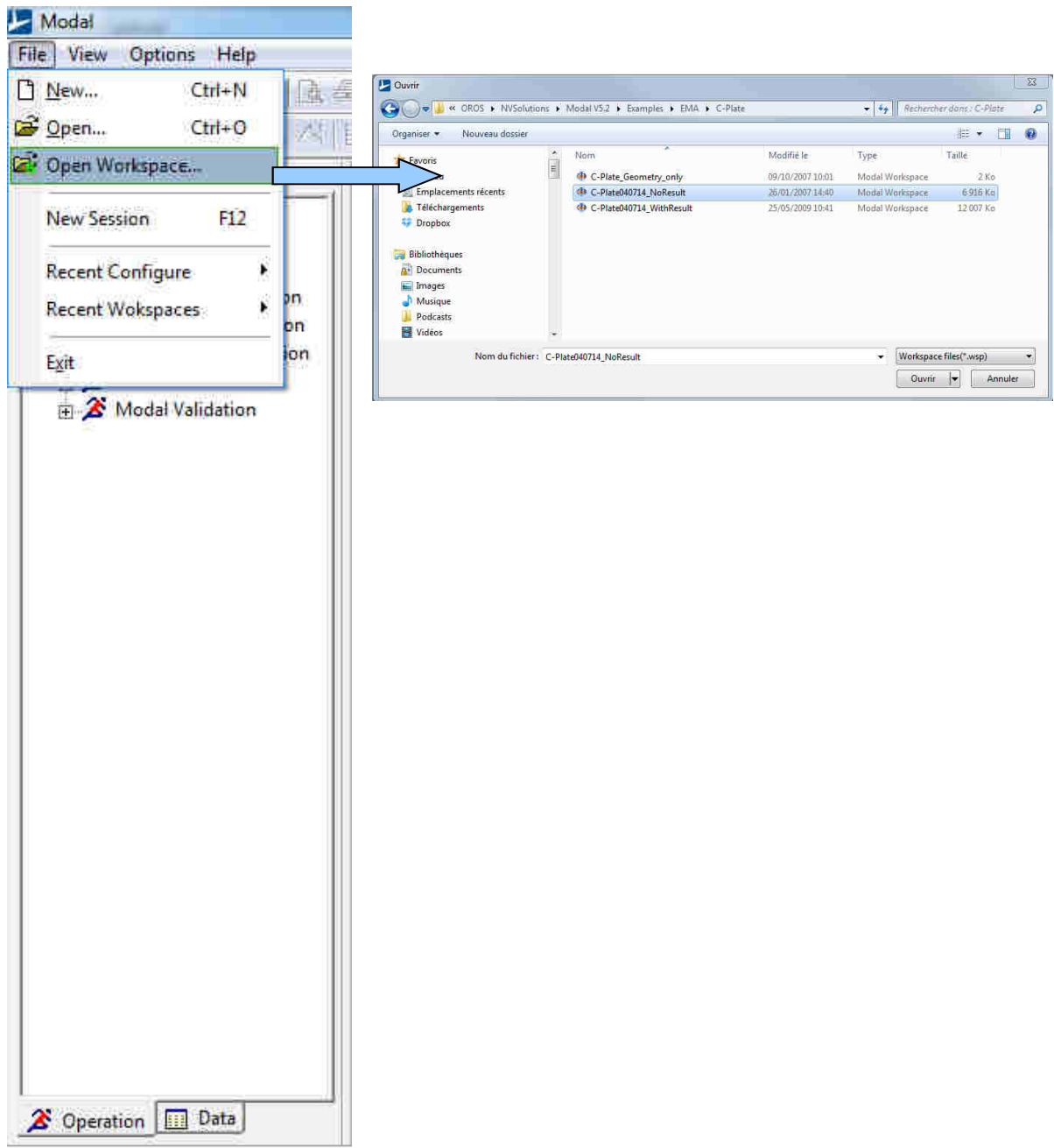

The main interface of the software is so displayed.

The window is shared in four distinct parts. Each of them has their own utilities.

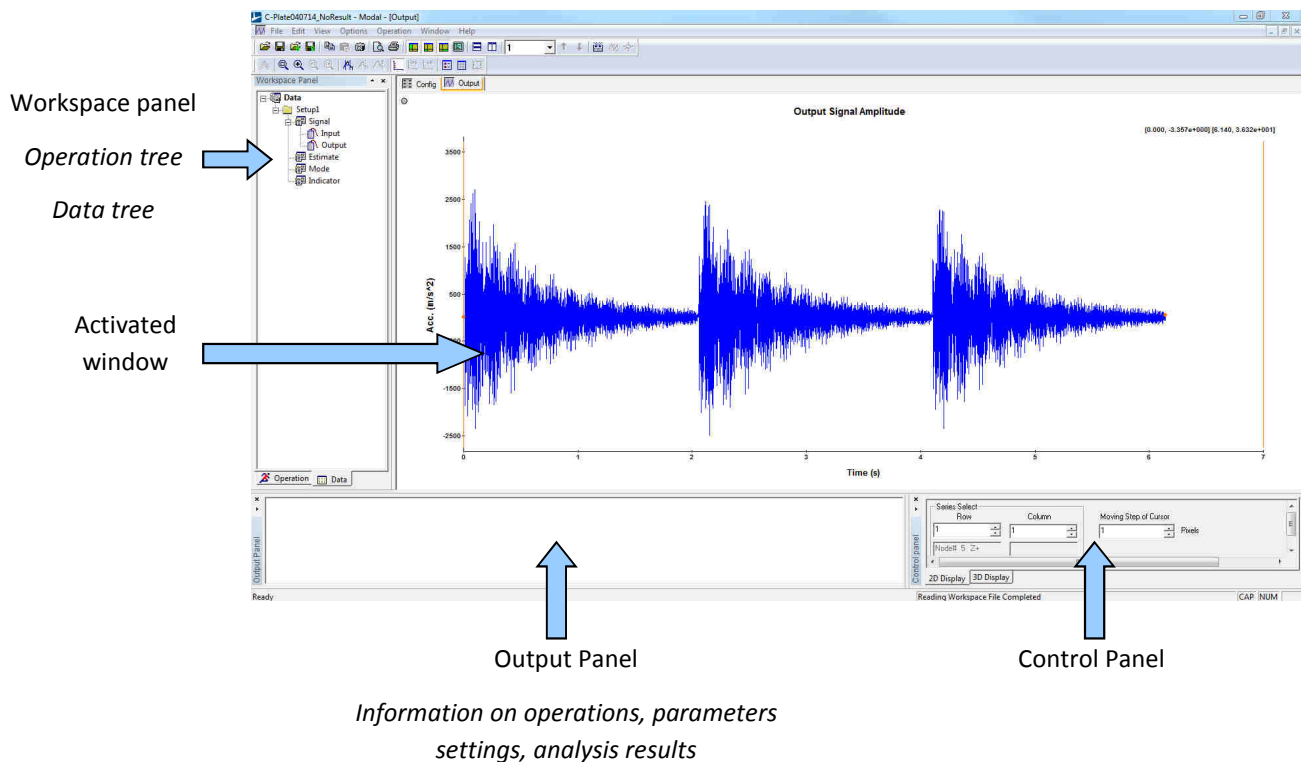

Workspace panel contains:

- an operation tree organized as a wizard to follow the different steps of a modal analysis
- a data tree where you can find all the data and results imported or calculated in the opened project.

Activated window can display:

- 2D windows: time domain data, FRFs estimation, curve-fitting...
- 3D windows: geometry, mode shapes.

Output Panel displays the last calculated results.

Control Panel contains the different commands and functions respectively useful for 2D and 3D windows.

TO KNOW MORE

To discover the different function of this software, please open the 'getting started' file installed at the same time than the software. You can follow the different steps described in the document to obtain some results very quickly.

The online help embedded within the software can help you and be also consulted for all kind of questions.

UPGRADE PROCEDURE

UPGRADES AVAILABLE

Several upgrade possibilities are available for this software. If you have already purchased a version of Modal and that you want to acquire other options several possibilities can be proposed to you.

Upgrades:

- ORNVS-MOD330u: ORNVS-MOD300 to ORNVS-MOD300

Add EMA SIMO Identification method

- ORNVS-MOD350u: ORNVS-MOD330 to ORNVS-MOD350

Add EMA MIMO Identification methods

Options

- ORNVS-MOD200: Acquisition available on all OROS 3-Series analyzers

Option allowing to do acquisition directly in Modal

- ORNVS-MOD180: OMA (Option to ORNVS-MOD300 or ORNVS-MOD330)

Add OMA Identification method

UPGRADE PROCEDURE

UPGRADE ORDER

If you order one of upgrades or options described above, a procedure should be followed:

Indeed, the number of the dongle is necessary to upgrade it.

You could find the number of your dongle directly written on it.

Please communicate it to OROS with your order simultaneously.

SOFTWARE UPGRADE

- Uninstall the previous version of Modal installed on the PC:

Insert the CD in the appropriate driver and wait for the Autorun program (or run the "setup.exe" program from the CD).

The following window is displayed:

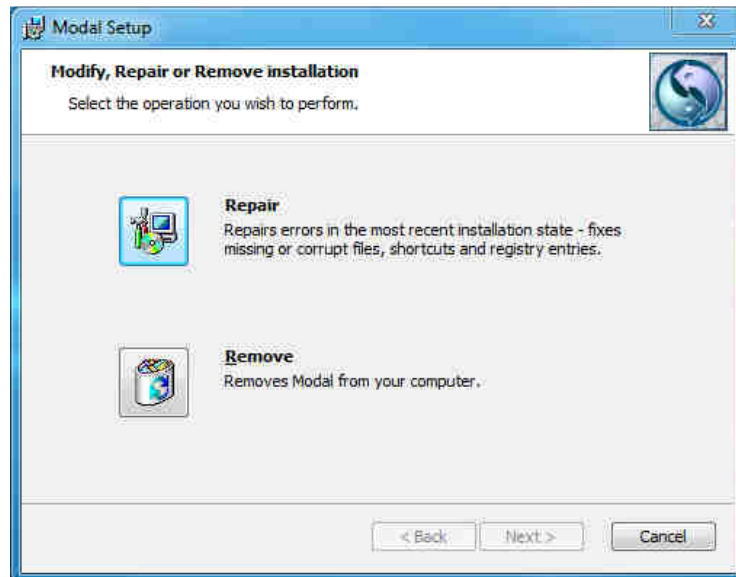

Click on Remove.

The following window is displayed:

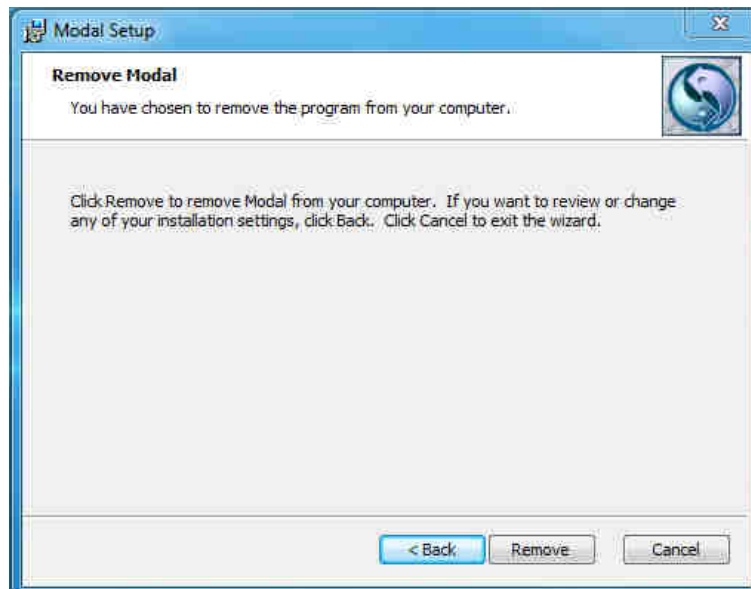

Click on remove.

The following window is displayed.

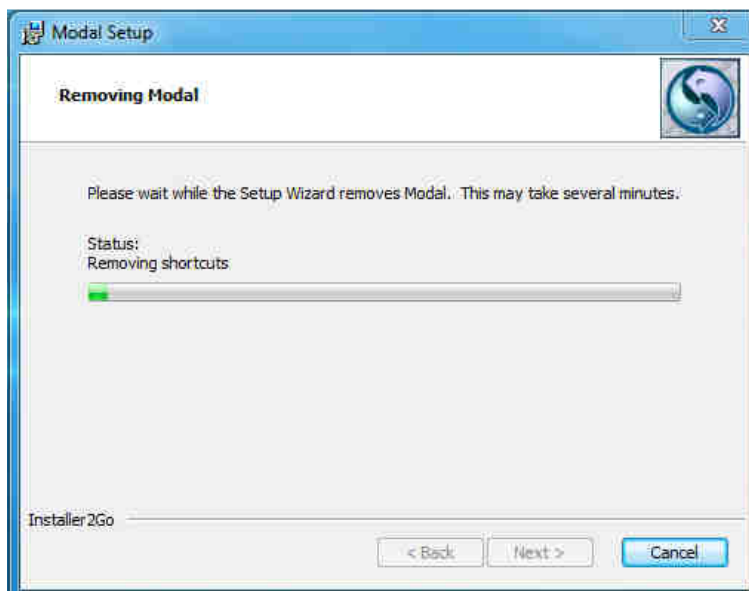

Wait during this window is displayed.

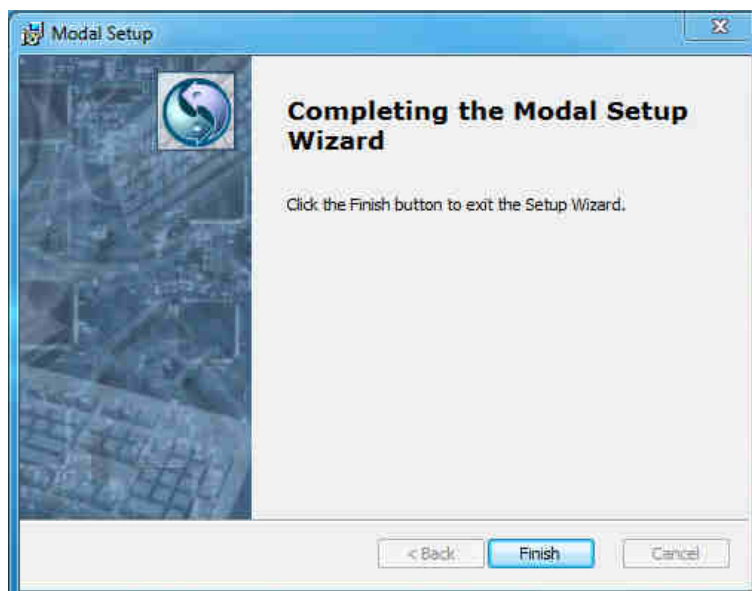

Click on finish.

Start the installation of the new version

Please follow the procedure described from page 8 to page 13.

DONGLE UPGRADE

Following your upgrade order, you will receive an upgrade file from OROS (.upg).

At this time open the DogInst application

The following window is displayed

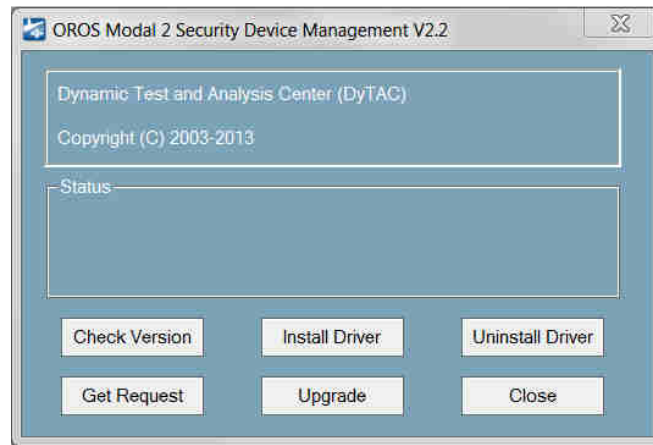

Click on 'Upgrade' and select the upgrade file you received.

The message 'Upgrade succeeded' will appear.

MODAL USER'S MANUAL

INTRODUCTION

Modal test and analysis is used to determine the engineering structures' modal parameters, such as modal frequencies, damping ratios, and mode shapes. The measured excitation and response (or only response) data are utilized in modal analysis, and then dynamic signal analysis and modal parameters identification are processed. The modal test and analysis has been developed for more than three decades, and much progress has been made. It has been widely applied to the engineering field, such as the dynamic design, manufacture and maintenance, vibration and noise reduction, vibration control, condition monitoring, fault detection, model updating and model validation.

OPERATING DEFLECTION SHAPE

Operating Deflection Shape (ODS) is the simplest way to see how a machine or structure moves during its operation, at a specific frequency or moment in time. There are two types of ODS: time domain ODS (TD ODS) and frequency domain ODS (FD ODS).

TD ODS is based on the multi-channel time history data acquired spatially from a machine or structure. It shows the vibration motion of the machine or structure in a period of time clearly, just like a recorder. You can view a structure's overall motion, and the motion of one part relative to another. Locations of excessive vibration are easily identified.

FD ODS is based on the frequency response functions (FRFs) or power spectral density functions (PSDs), which can be estimated from multi-channel time history data acquired spatially from a machine or structure. It shows how a structure behaves at a single frequency, helping you to find whether or not a resonance is being excited. In the OROS Modal, you even be allowed to inside the different behaviors of repeated frequencies.

EXPERIMENTAL MODAL ANALYSIS

In the Experimental Modal Analysis (EMA), the structures are excited by artificial forces, then both the inputs (excitation) and outputs (response) are measured to get the frequency response functions (FRFs) or impulse response functions (IRFs) by digital signal processing. Modal parameters can be identified from FRFs or IRFs by identification algorithms in frequency domain or time domain. EMA tests are usually carried out in the lab, with the advantage of high SNR (Signal to Noise Ratio) and easy to change test status.

EMA identification methods can be classified into time domain (TD) methods and frequency domain (FD) methods according to different identification domain. Also they can be classified into SISO (single input single output), SIMO (single input multiple output), and MIMO (multiple input multiple output) according to different number of input and output.

The FRFs are generally utilized for the EMA in frequency domain, which are estimated from the excitation and response signals. Then the modal parameters are identified by constructing the parametric or nonparametric models of the FRFs and curve fitting them. While the IRFs are generally utilized for the EMA in time domain, which can be obtained the inverse FFT of FRFs.

Time domain methods are suitable for the global analysis in a broad frequency band, which have good numeric stability. However, there are some limitations too: (1) very difficult to confirm the order of math model, (2) always time consuming, (3) many calculation modes got with the structural modes, and

difficult to delete them, (4) many setting and judgment needed, complicated-to-use, (5) not able to taking account of the influence of out-band modes. Contrarily, frequency domain methods are always reliable, rapid, easy-to-use, with the capacity to consider the out-band modes and analysis uneven spaced FRFs, so they are applied widely.

OPERATIONAL MODAL ANALYSIS

Operational Modal Analysis is used for large civil engineering structures, operating machinery or other structures, making use of their output response only. These structures are always loaded by natural loads that cannot easily be controlled and measured, for instance waves loads (offshore structures), wind loads (Buildings) or traffic loads (bridges).

Compared with EMA, OMA has its outstanding advantages. In OMA the structure studied is excited by natural loads instead of some expensive excitation equipments as used in EMA. In fact it is very difficult to excite large structures by artificial means. So OMA is more economic and fast, and endowed by nature with characteristics of multiple-input / multiple-output (MIMO). It could be used to distinguish closely coupled modes. Moreover, all the measured responses come under operational state of structures, and their real dynamic characteristics in operation could be revealed, so OMA is very suitable for health monitoring and damage detection of large-scale structures.

Because there are limited channels and accelerometers in a data acquisition system, you may need to decide how to distribute the many measurement points in several groups, the so-called setups. For each setup you should keep 1 or more accelerators at the same location, which are called reference points. The reference points should be located far away the nodal points of the mode shapes. It is recommended to set 2 or 3 reference points.

MODAL SOFTWARE FEATURES

- Running on the current mainstream Operating systems: Windows 2000/XP/2003 Server/Vista
- Coding with VC++ language and object oriented programming technique, easy to be maintained and expanded
- Four powerful functions: geometry modeling, project management, dynamic signal processing, and modal analysis
- Convenient data importing interface, not only for time domain signal, but also frequency domain signal
- Direct data acquisition from OR3x series analyzers, performing a modal test easily and rapidly
- Various data format: Modal standard file format, Universal File Format (UFF) and OROS format (res, oxf, or oxl)
- Integrated functions for geometry modeling
 - o Import geometry from UFF or IGES files
 - o Export geometry to UFF files
 - o Create regular 3D geometry objects
 - o Create and edit geometry interactively
 - o Undo and redo operations for geometry edit
 - o Customized geometry library

- Combined with all kinds of data acquisition systems or dynamic signal analyzers to make up advanced modal analysis systems
- Powerful, effective and easy-to-use signal processing based on wizard setting
 - o Detrend, decimation and digital filter
 - o Customized FFT parameters: FFT length, average times, and overlap percent
 - o All kinds of window function: boxcar, hanning, hamming, flattop, exponential, force and so on
 - o Power Spectrum Density (PSD) estimation: Auto PSD, Cross PSD, PSD matrix, using Welch's averaged periodogram technique
 - o Single input / multiple output (SIMO) FRF estimation: H1, H2 and Hc methods
 - o Multiple input / multiple output (MIMO) FRF estimation with multiple coherence function
 - o The signal processing is reversible
- Dealing with not only traditional Experimental Modal Analysis (EMA), but also Operational Modal Analysis (OMA)
- EMA techniques based on both input (excitation force) and output response
 - o Select-band SIMO modal analysis technique: SIMO rational fraction orthogonal polynomial (RFOP), to obtain several modes from a selected frequency band by one identification
 - o Narrow-band MIMO modal analysis technique, MIMO complex mode indicator function (CMIF), to identify modes one by one
 - o Select-band MIMO modal analysis technique: frequency domain poly-reference (FDPR) and MIMO rational fraction orthogonal polynomial (RFPM), to obtain several modes from a selected frequency band by one identification
 - o Broad-band MIMO modal analysis technique: EMA broad band frequency domain (EBFD) , to obtain many modes from a broad frequency band by one identification, or even obtain all the modes from the full frequency band by one identification
 - o MIMO analysis methods: with capacity to identify heavy close or even repeated modes, ideal methods for experimental modal analysis of large and complicated structures
 - o Single reference (SR) and Multiple References (MR) hammer impact modal analysis techniques
- OMA techniques base on output data only
 - o Valuable for the large civil engineering structures, operating machinery or other structures which are not easily excited artificially; cheap and fast, without requirement for excitation equipment; able to get the dynamic characters of structures in real operating conditions
 - o Narrow-band operational modal analysis technique: frequency spatial domain decomposition (FSDD), to obtain modes one by one from the full output spectrum matrix
 - o Narrow-band operational modal analysis technique: complex mode indicator function (CMIF), sharing the same algorithm with EMA Narrow-band, to obtain modes one by one from the half output spectrum matrix

- Broad-band operational modal analysis technique: OMA broad band frequency domain (OBFD), to obtain many modes from a broad frequency band of the half output spectrum matrix by one identification, or even obtain all the modes from the full frequency band by one identification
- Adopting mode indicator function (MIF) to indicate the existence of structural modes
- Unlimited number of identified modes
- Flexible interface arrangement and various mouse and hotkey operation, thereby greatly improving work efficiency
- Perfect and friendly function for arranging interface, operating and exporting data
 - Multiple language interface: English and Chinese are available, and it's convenient to develop other language interface
 - Special 2D and 3D graphic control panes, supplemented with other control modes such as mouse, hotkey, and menu operations
 - Flexible 2D curves display and control: showing or hiding gridlines, legends and other components, providing complete measurement information (measurement node, direction, whether driving point or not, and so) of each plot
 - Multiple curve expressions: magnitude (linear, log, and dB coordinate), phase, unwrapped phase, real part, imaginary part, and Nyquist
 - Flexible 3D graphics display and control: showing or hiding node ID, input / output tags, axis and other components, freely translating, zooming and rotating the object
 - Top, bottom, left, right, front and back view of 3D objects, rendering in the style of frame lines or surface
 - Animation control based on OpenGL: play, stop, previous/next frame, amplitude and speed control functions
 - Exporting the modal results to text or graph
 - Directly saving all the curves or graphics to BMP or JPG files
 - Exporting the mode animation to AVI media files, convenient to generate multimedia presentation

ENVIRONMENT

GENERAL INTERFACE

When Modal is running, the following interface will be displayed.

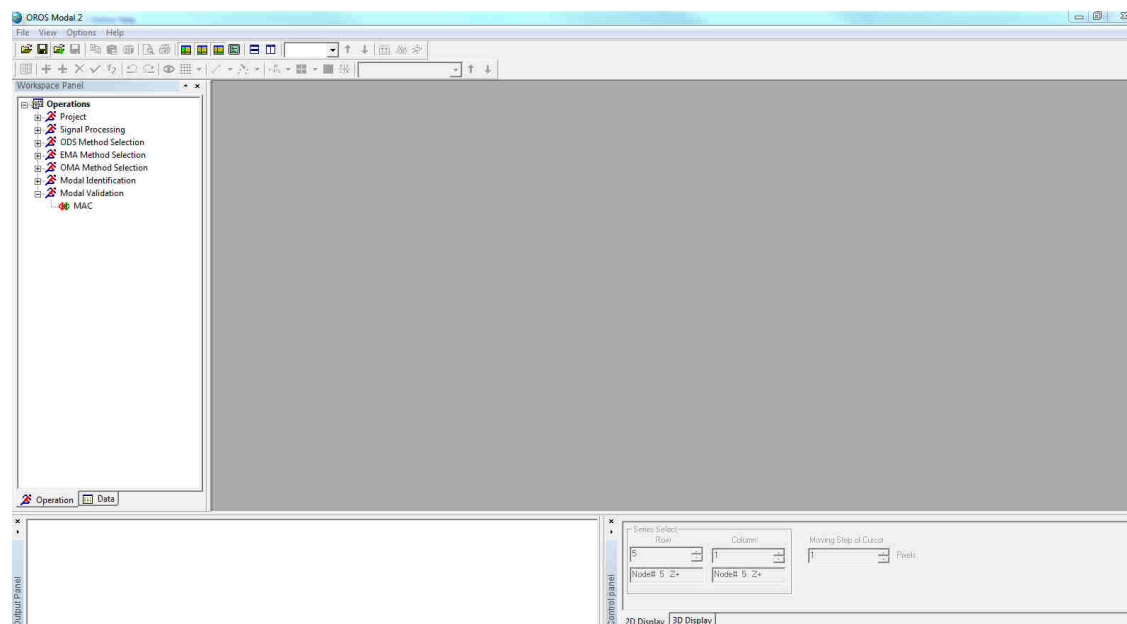

The menus, toolbars, workspace panel, output panel and control panel are listed from top to bottom. The center empty area of the interface is reserved for the main window. The workspace panel, output panel and control panel are generally called shortcut panels. The state bar locates in the bottom of window. The menus' tips, processing bar and its tips are all showed on the state bar.

When you create a new configuration file or open a workspace file without measurement data, the 'Config' window will first be shown.

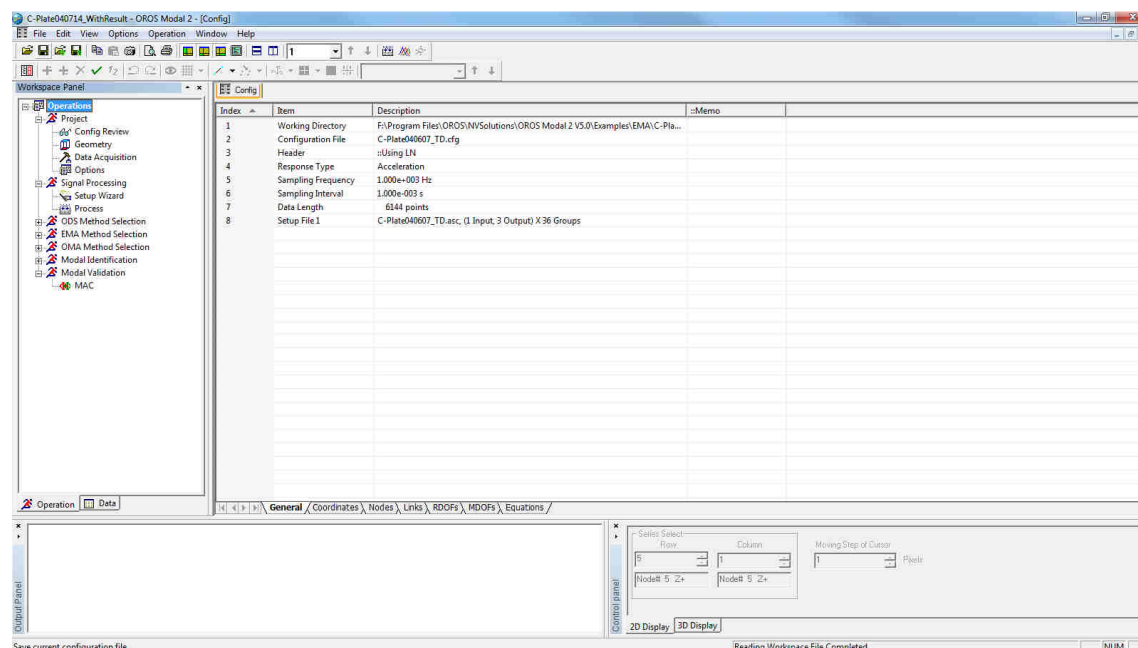

When users open a configuration file or workspace file with measurement data, the 'Output' curve window will first be shown. There are two cursors on the left and right of the window respectively. The red point denotes the closest point to the cursor. The X and Y axes values of the two red points are shown dynamically on the top right corner of the window.

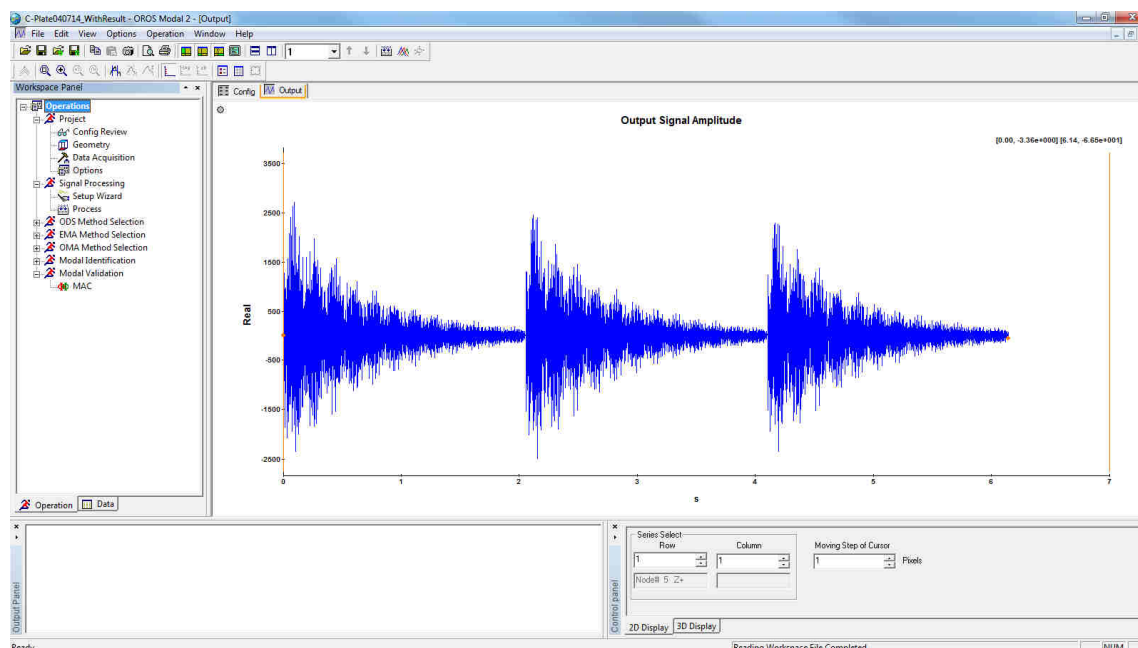

Each part of the interface can be shown or hidden through menu or toolbar operation. Users can also change the size or positions of each part by dragging the mouse.

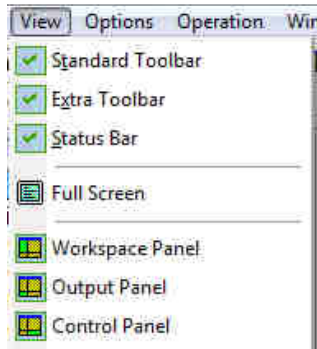

Besides, all parts of the interface can be arranged to floating style for the purpose of getting more display space.

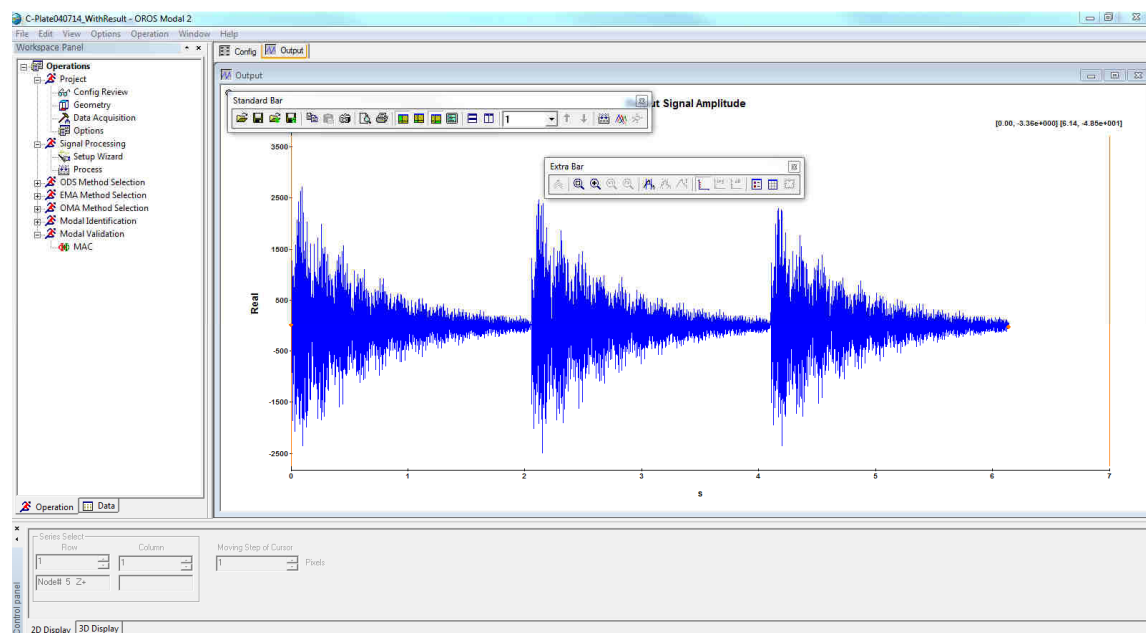

The software can also remember the adjusted interface style automatically in order to fit users' habits.

GEOMETRY MODELLING

PRINCIPLE

To begin with the geometry modeling, we should know about three important concepts, i.e. coordinates, nodes and links. A geometry is made up of these three elements.

COORDINATES

GLOBAL AND LOCAL COORDINATES

There are two kinds of coordinate systems in Modal, i.e. the global coordinate system and local coordinate system. The global coordinate system which defines the global origin point and global X, Y, and Z axis, is a kind of Cartesian coordinate. The No. of global coordinate system is 0 in Modal. The local coordinate systems are all defined referring to the global coordinate. Three kinds of local coordinate systems are available now, i.e. the Cartesian coordinate, the cylindrical coordinate and the spherical coordinate. You can have only one global coordinate, but many local coordinates. All the coordinates in Modal are defined according to the right-hand rule.

CARTESIAN COORDINATE

To define a point in the Cartesian coordinate system, you need three translations x , y , and z as the following:

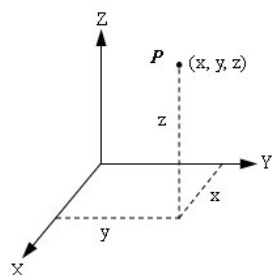

CYLINDRICAL COORDINATE

To define a point in the Cylindrical coordinate system, you need radius x , rotation y , and translation z , as the following:

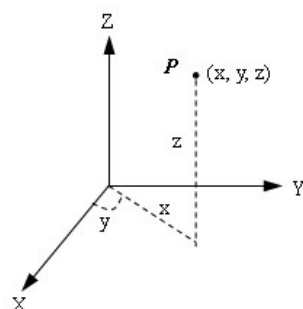

SPHERICAL COORDINATE

To define a point in the Spherical coordinate system, you need radius x , rotation y , and rotation z , as the following:

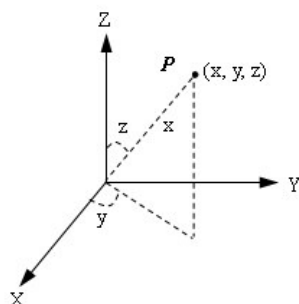

It's easy to transform between these three coordinate systems.

DEFINE A COORDINATE

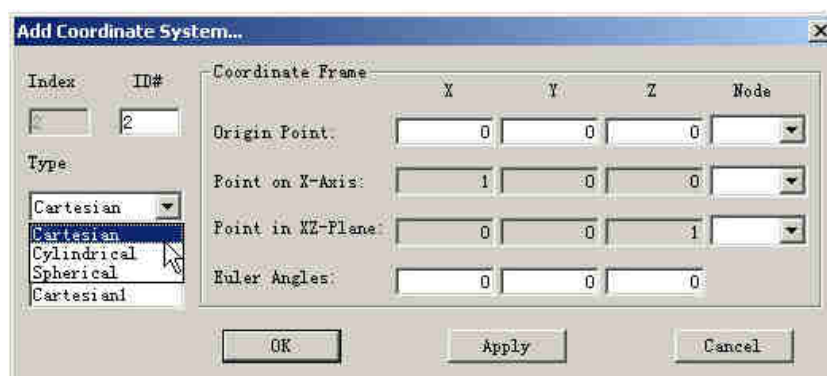

To define a local coordinate system, you should assign an ID No., select the coordinate type, and specify the position and direction of local coordinate frame. A local coordinate $O_L X_L Y_L Z_L$ is always defined referring to the global coordinate $OXYZ$. In Modal, three points are employed to specify the coordinate frame, i.e. the original point P_1 , a point P_2 on the X_L axis, and another point P_3 on the $X_L Z_L$ plane. For convenience, the point P_3 is usually selected on the local Z_L axis.

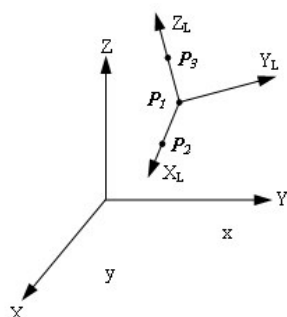

As shown in the above picture: the local X_L axis can be determined by P_1 and P_2 ; the plane $X_L Z_L$ can be determined by P_1 , P_2 , and P_3 , thus the Z_L axis can also be obtained; the Y_L axis can then be determined according to the right-hand rule.

You can also define a local coordinate system by the origin point and three Euler angles.

NODES

DEFINE A NODE

A node must belong to a coordinate, either the global coordinate system or a local coordinate system. Besides the coordinate ID, you still need to specify its No. and x, y, z values.



DIRECTIONS OF A NODE

In Modal, it's very important that the directions of a node are defined in the local coordinate system.

In a local Cartesian coordinate, all the points have the same directions with local axis. These three directions accord with right-hand rule.

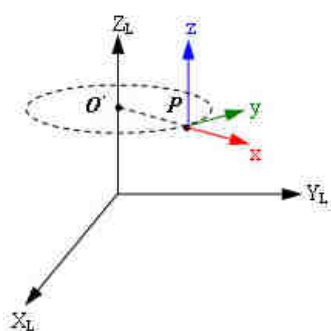
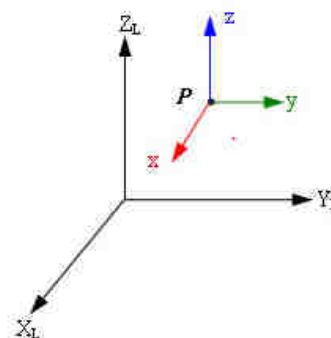

In a local cylindrical coordinate:

the x direction vector start from the cross point O' to node point P ; the z direction is the same as local Z_L axis; and the y direction is tangential to the circle. These three directions accord with right-hand rule.

In a local spherical coordinate: the x direction vector start from the origin point to node point P ; the y direction is tangential to the longitude circle; and the z direction is tangential to the latitude circle. These three directions accord with right-hand rule.

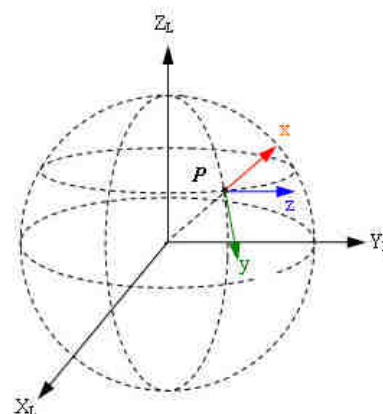

LINKS

Two types of link are supported in Modal: lines and polygons.

A line is defined by two nodes. For instance, "3 5" defines a trace line between node 3 and node 5.

A polygon is defined by a sequence of nodes. You are allowed to define a polygon with arbitrary number of nodes, which should be arranged according to the clockwise or anticlockwise direction. For instance, "1 2 3 4 5 6" defines a hexagon.

GEOMETRY IN MODAL SOFTWARE

To build a geometry model in the Modal software, you have three methods at least:

- Use the integrated function for geometry modeling in Modal
- Import geometry from UFF files;
- Create geometry information in the Excel, and then copy and paste them to the "Config" view.

GEOMETRY MODELING ILLUSTRATION

In this section, the process of creating an uneven spaced plate is introduced.

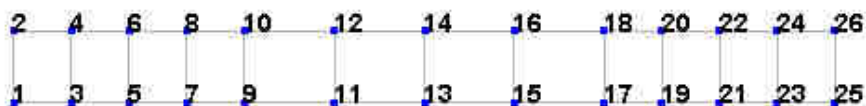

The plate is 10 in width, and 114 in length, which is divided into 12 segments. The first 4 segments (A) and last four segments (C) are evenly distributed with an interval of 8, and the middle 4 segments (B) are evenly distributed with an interval of 12.5. To ensure the nodes numbered continuously, the following steps should be processed:

- Segment A. The parameters should be set as below:

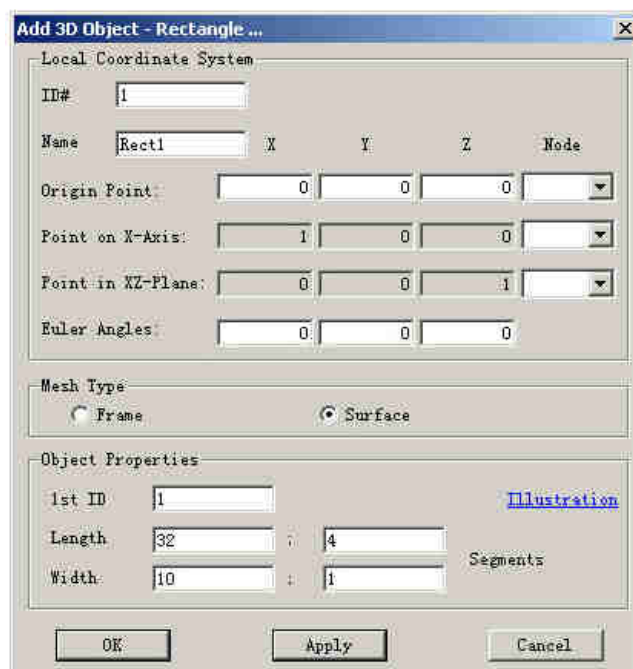

The structure showed as below is got :

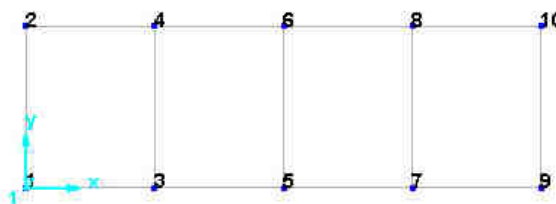

- Segment B. The origin point of segment B should be node 9. The value of Point on X-Axis and Point in XZ-Plane will be changed automatically.

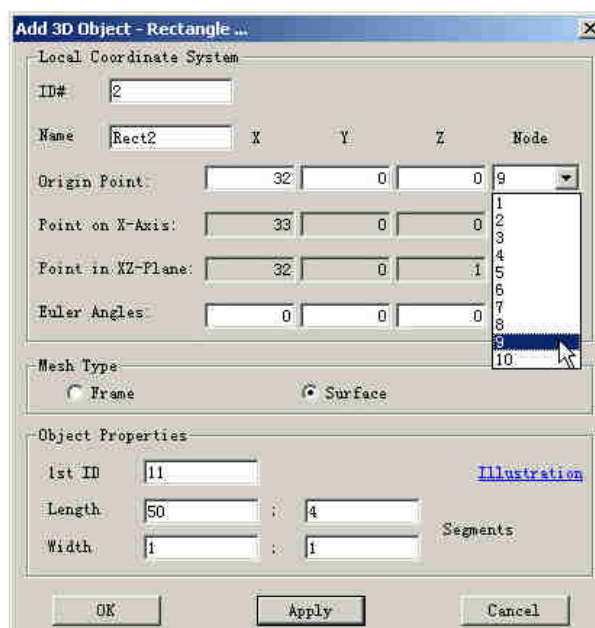

The structure showed as below is got :

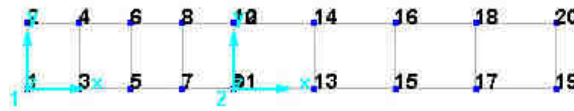

- Segment C. The origin point of segment C should be node 19. The value of Point on X-Axis and Point in XZ-Plane will be changed automatically.

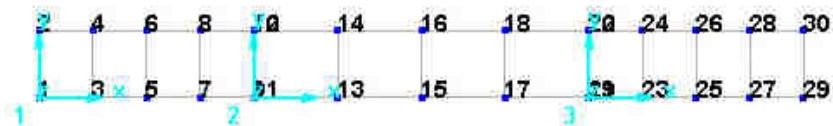
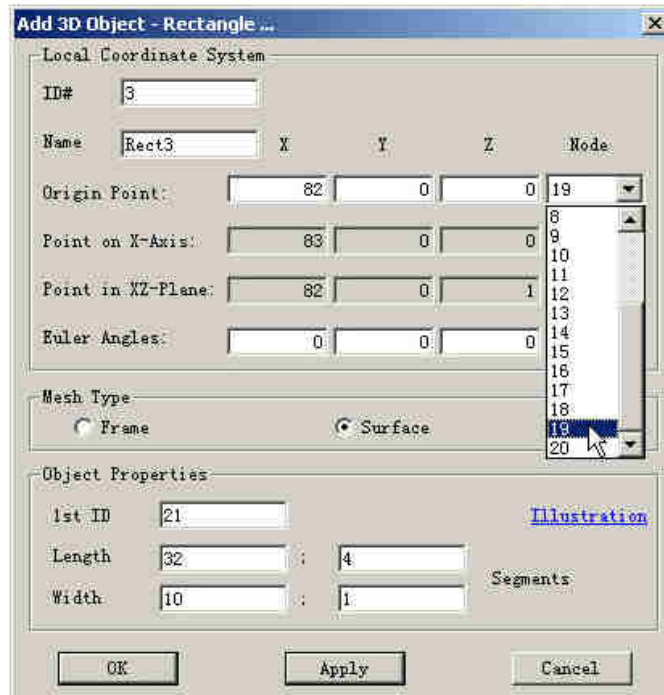

- Note that there are some repeated nodes, for example, node 9 and node 11, node 10 and node 12. Remove all the repeated nodes by pressing the button of "validity check" .

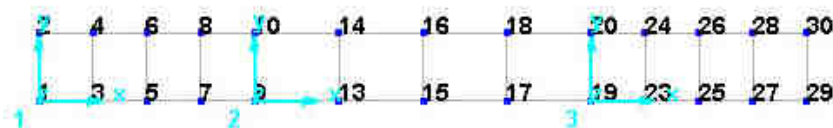

- Note that the IDs of nodes are not continuous now. Renumber all the nodes in-order by pressing the button . The task of modeling has been accomplished by now.

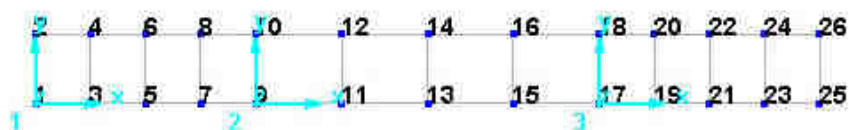

BASIC GEOMETRY LIBRARY

Geometry modeling is realized in the "Config" view or 3D "Geometry" view by operating the relevant toolbar and right click menu. The location, shape, mesh and numbering of a 3D object can be totally specified by setting its local coordinate system, mesh type, first ID and properties. Several internal 3D objects are included in Modal, such as Line Segments, Line, Rectangle, Trapezia, Sector, Elliptic Sector, Cube, Elliptic Cylinder, Cone, and Sphere.

When bundling several 3D objects together, there may exist some repeated nodes, which will lead to some problems. It's recommended to delete these repeated nodes. You can finish this task conveniently in Modal.

LOCAL COORDINATE SYSTEMS

Each new 3D object will be created with a new local coordinate, whose type depends on the different kinds of object. You should define the origin point and coordinate frame in the below interface.

The local coordinate is determined by three geometry point in Modal.

Local Coordinate System					
ID#	1				
Name:	Rect1	X	Y	Z	Node
Origin Point:	0	0	0		
Point on X-Axis:	1	0	0		
Point in XZ-Plane:	0	0	1		
Euler Angles:	0	0	0		

The ID# will be specified automatically. Of course you can change it if necessary. You can type the three points manually, or select an existed node from the "Node" list. If a node is selected, its global coordinate value will be filled into the blanks automatically.

Note: On the icons for adding 3D objects in the toolbar, the light blue point indicates the origin of local coordinate system. For example, the icon  indicates that the origin of a rectangle object lies in its bottom left corner.

Moreover, there is hyperlink text of "Illustration" on the dialog of setting properties. Illustration graph of 3D object to be added will show when moving cursor on it.

MESH TYPE

Mesh Type	
<input type="radio"/> Frame	<input checked="" type="radio"/> Surface

This option allows you to set the mesh type to frame or surface. If the surface type is selected, the meshed can be rendered. For a line object, only the frame type is optional.

1ST ID

This option allows you to set the first node ID of a new 3D object. Modal automatically assigns the 1st ID for the new object. It's recommended to set this parameter equal or large than the default value for a primary user.

Of course, in some occasions, setting the 1st ID flexibly will greatly reduce the workload for an advanced user.

PROPERTIES

- Line Segments

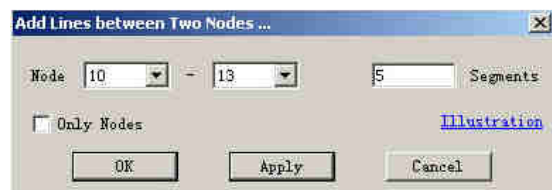

Add line segments between two specified nodes. If "Only Nodes" is checked, then the links will not be added.

- Line

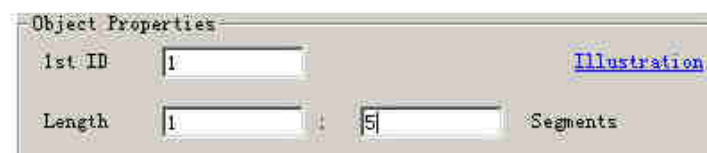

Only the length and number of segments are required for a line object. The line is along the X axis of local coordinate, and its local origin locates in the left fringe. The node IDs are increasing from its left to right. The new coordinate is of Cartesian type.

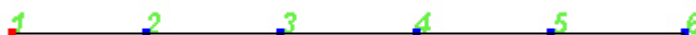

- Rectangle

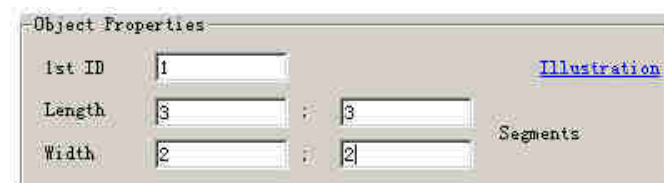

Length, width and their number of segments should be specified for a rectangle object. The local origin of a rectangle object locates in its bottom left corner. The node IDs are increasing from its left to right. The nodes are numbered from the origin, in the turn of from left to right and from bottom to top. The new coordinate is of Cartesian type.

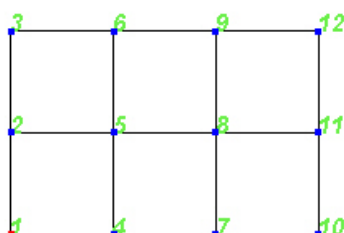

- **Trapezia**

Object Properties			
1st ID	<input type="text" value="1"/>	Illustration	
Upper Length	<input type="text" value="1.5"/>		
Nether Left	<input type="text" value="0.6"/>	:	<input type="text" value="3"/>
Nether Right	<input type="text" value="1.2"/>		
Height	<input type="text" value="1"/>	:	<input type="text" value="2"/>

Upper side length, nether left side length, nether right side length, height and their number of segments should be specified for a trapezia object. The local origin of a trapezia object is the intersection point of left height line and nether side, which is shown as the red point in the figure below. The nodes are numbered in the turn of from bottom to top and from left to right. The new coordinate is of Cartesian type.

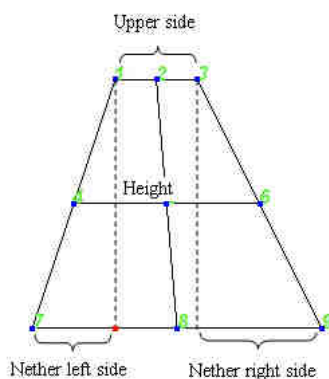

If the length of nether left side or nether right side is equal to zero, it's a right-angle trapezia. If both of them are equal to zero, it's a rectangle. If the length of upper side is equal to zero, it's a triangle.

- **Sector**

Object Properties			
1st ID	<input type="text" value="1"/>	Illustration	
Sector Angle	<input type="text" value="120"/>	:	<input type="text" value="8"/>
Inner Radius	<input type="text" value="1"/>	:	<input type="text" value="3"/>
Outer Radius	<input type="text" value="3"/>		

The shape of a sector object is specified by the sector angle, inner radius and outer radius. To mesh the sector you should set the number of segments of sector angle and radius. The local origin of a sector object is right the circle center. The sector object is distributed symmetrically to the Y axis of local coordinate system. The nodes IDs are increasing from inner to outer in the anticlockwise direction. The new coordinate is of Cylindrical type.

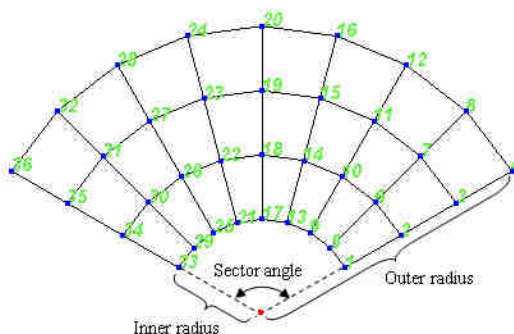

If the sector angle is equal to 360 degrees, it's a hollow cirque. If the inner radius is equal to zero, it's a solid sector. If the sector angle is equal to 360 degrees, and the inner radius is equal to zero, it's a solid circle.

- Elliptic Sector

Object Properties			
1st ID	<input type="text" value="1"/>		Illustration
Sector Angle	<input type="text" value="270"/>	<input type="text" value="12"/>	Segments
Long Axis	<input type="text" value="2.5"/>	<input type="text" value="2"/>	
Short Axis	<input type="text" value="1"/>	<input type="text" value="2"/>	

The shape of an elliptic sector object is specified by the sector angle, long radius and short radius. To mesh the elliptic sector you should set the number of segments of sector angle and radius. The local origin of a elliptic sector object is right the ellipse center. The nodes IDs are increasing from inner to outer in the anticlockwise direction. The new coordinate is of Cartesian type.

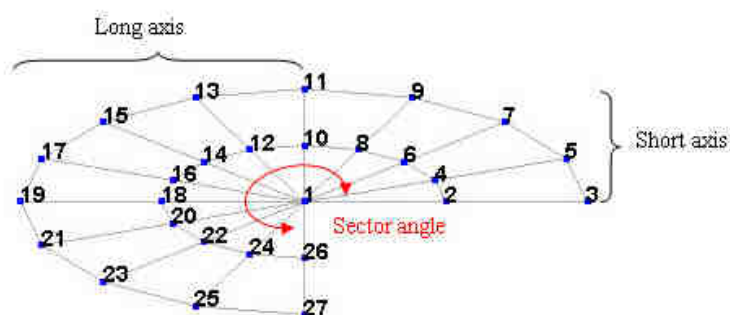

If the sector angle is equal to 360 degrees, it's an ellipse. If the long radius is equal to the short radius, it's a circle sector, which is the same as the [sector](#) object introduced above. If the sector angle is equal to 360 degrees, and the long radius is equal to the short radius, it's a solid circle too.

- Cube

Object Properties			
1st ID	<input type="text" value="1"/>		Illustration
Length	<input type="text" value="4"/>	<input type="text" value="4"/>	Segments
Width	<input type="text" value="3"/>	<input type="text" value="3"/>	
Height	<input type="text" value="2"/>	<input type="text" value="2"/>	

Length, width, height and their number of segments should be specified for a cube object. The local origin of a cube object locates in the nether left corner of the front side, which is shown as the red point in the figure below. The nodes are numbered from the origin, and the IDs are increasing from nether to upper in the anticlockwise direction. The new coordinate is of Cartesian type.

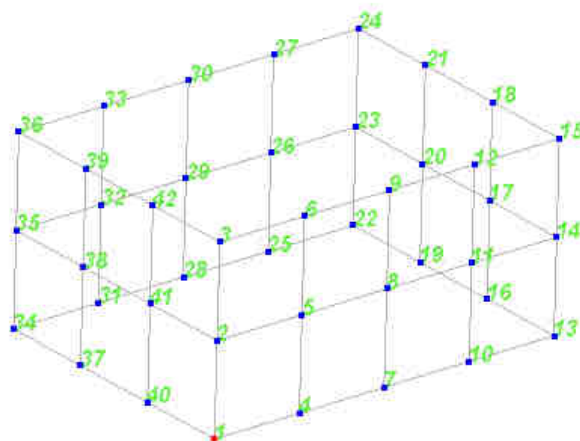

There is neither top side nor bottom side in this cuboid object. If necessary, you can bundle this object with two [rectangle](#) objects, and then remove the repeated nodes to get a cube with all six sides. If the length, width and height are all equal, it's a cube.

- **Elliptic Cylinder**

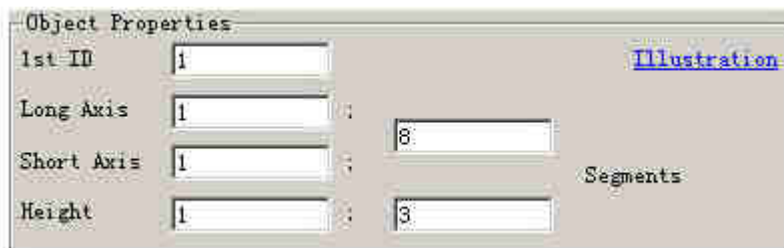

Long axis and short axis and height should be specified for an elliptic cylinder object. To mesh this object you should set the number of segments of circumference and height. The local origin of an elliptic cylinder object is right the ellipse center of bottom side. The nodes are numbered from the Y axis of local coordinate, and the IDs are increasing from bottom to top in the anticlockwise direction. If the cross section is a circle, the new coordinate is of Spherical type. If the cross section is an ellipse, the new coordinate is of Cartesian type.

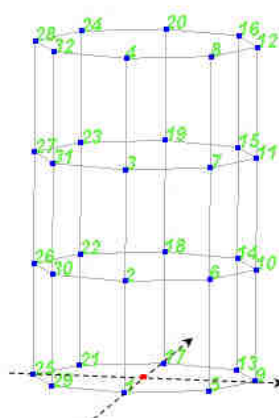

There is neither top side nor bottom side in this elliptic cylinder object. If necessary, you can bundle this object with two [sector](#) or [elliptic sector](#) objects, and then remove the repeated nodes to get a elliptic cylinder with top and bottom sides.

If the long axis is equal to the short axis, it's a common cylinder.

- **Cone**

Object Properties		
1st ID	<input type="text" value="1"/>	Illustration
Upper Radius	<input type="text" value="1"/>	Segments
Nether Radius	<input type="text" value="2"/>	
Height	<input type="text" value="3"/>	<input type="text" value="12"/>
		<input type="text" value="2"/>

Upper radius, nether radius and height should be specified for frustum of a cone object. To mesh this object you should set the number of segments of circumference and height. The local origin of a cone object is right the circle center of bottom side. The nodes are numbered from the Y axis of local coordinate, and the IDs are increasing from bottom to top in the anticlockwise direction. The new coordinate is of Cylinder type.

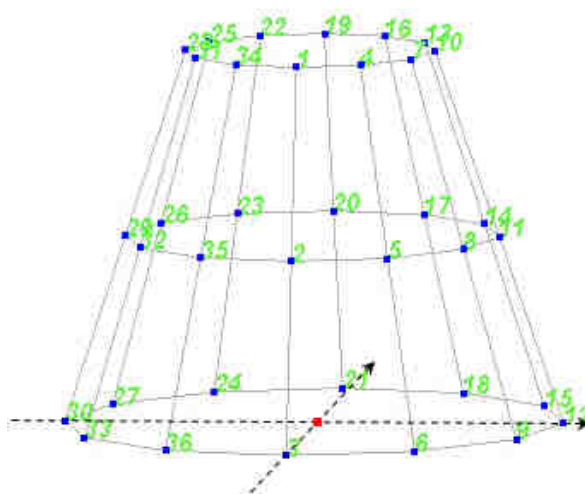

There is neither top side nor bottom side in this cone object. If necessary, you can bundle this object with two [sector](#) or [elliptic sector](#) objects, and then remove the repeated nodes to get a cone with top and bottom sides.

If the upper radius or nether radius axis is equal to zero, it's a complete cone (not a frustum).

- **Sphere**

Object Properties		
1st ID	<input type="text" value="1"/>	Illustration
Radius	<input type="text" value="1"/>	Segments
	<input type="text" value="12"/>	
Lat. Angle	<input type="text" value="-30"/>	<input type="text" value="6"/>
	<input type="text" value="90"/>	

Radius and range of latitude angle should be specified for frustum of a sphere object. The range of a latitude angle is $[-90,90]$ degree. Latitude angle of zero means the equator. Latitude angle of -90 degree means the south pole. Latitude of 90 means the north pole. To mesh this object you should set the number of segments of circumference and latitude angle. The nodes are numbered from the negative Y axis of south latitude plane in the local coordinate, and the IDs are increasing from south to north in the anticlockwise direction. The new coordinate is of Spherical type.

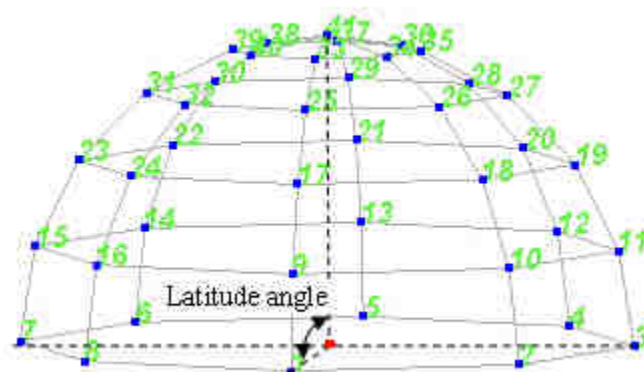

If the latitude angle is greater than -90 degree and less than 90 degree, it's the frustum of a sphere. There is neither top side nor bottom side in this cone object. If necessary, you can bundle this object with two [sector](#) or [elliptic sector](#) objects, and then remove the repeated nodes to get a complete frustum of sphere. If the latitude angle ranges from -90 degree to 90 degree, it's a complete sphere. If the latitude angle ranges from zero to 90 degree, it's a hemisphere.

INTERACTIVE GEOMETRY MODELLING

Modal also provides you with functions of interactive geometry modeling. You can add nodes, lines, polygons and 3D objects just by mouse clicking, and realize operations of translation, zoom, rotation, deletion, and so on. The functions are accessible by the Graphics Extra Toolbar.

The graphics extra toolbar is available only when geometry, mode shape or ODS animation are showed in the current main window. It is used to control the 3 dimension graphics and animations. This toolbar is the same as configuration extra toolbar, only different buttons are enabled, and its floating style is as below:

The functions of each button as follows:



: Show the interface for geometry modeling



: Delete the selected items



: Check all items, and remove the repeated nodes



: Renumber all the nodes in-order



: Undo the last action





: Redo the previous undone action



: Reset the layout to show the objects in window



: Show the grid plane or not. There is a dropdown menu below this button:

 Show Grid	: Show the grid plane or not
 Snap to Grid	: Snap to grid point
 Grid Setting...	: Call the dialog to set the parameters of grid plane

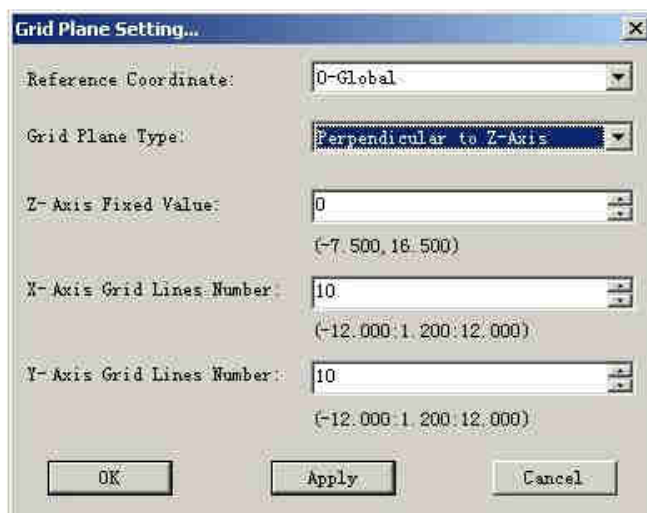

Referring to the global coordinate or some local coordinate, the position of the grid plane can be set by changing the parameters in the dialog. With the grid plane, you'll be convenient to edit the geometry, such as adding a node or moving a node. Note that the coordinate values displayed are all relative to the reference coordinate, and in the format of Cartesian, even if the reference coordinate is of cylinder or sphere type.



: Add line segments between two nodes. There is a dropdown menu below this button:

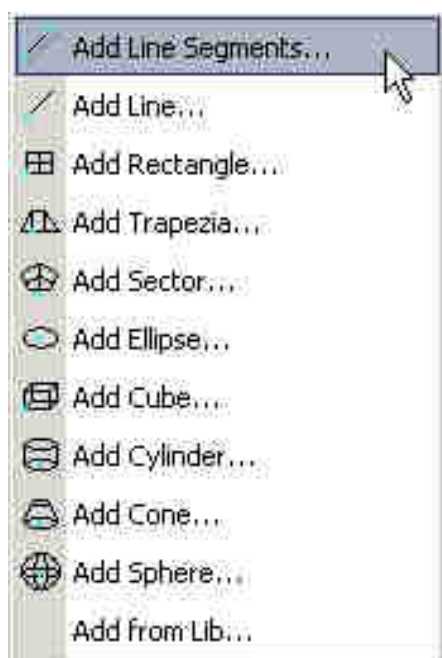

: Add line segments between two nodes

: Add a line to the structure

: Add a rectangle to the structure

: Add a trapezia to the structure

: Add a sector to the structure

: Add an ellipse to the structure

: Add a cube to the structure

: Add a cylinder to the structure







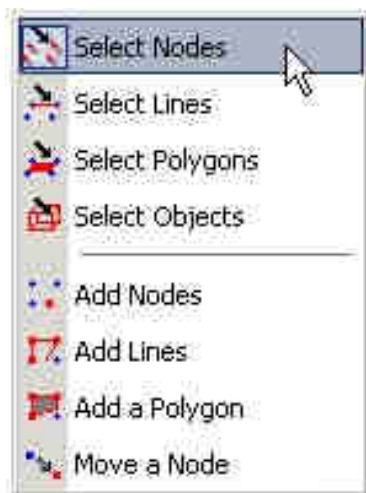

: Add a cone to the structure

: Add a sphere to the structure

: Add a 3D object from the geometry library

 : To select nodes by mouse. There is a dropdown menu below this button:



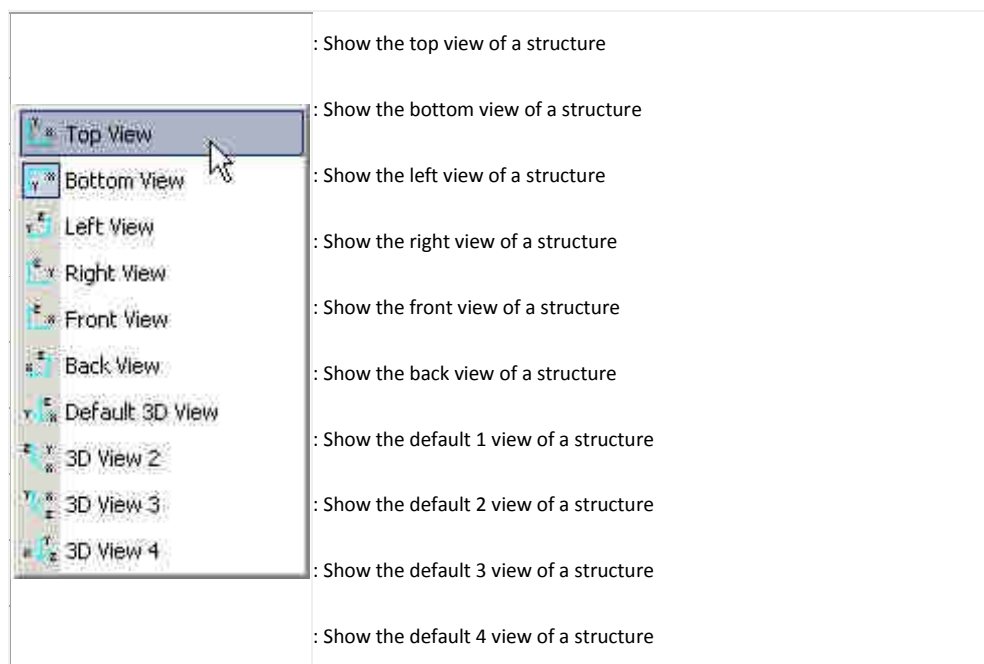

-  : To select nodes by mouse
-  : To select lines by mouse
-  : To select polygons by mouse
-  : To select 3D objects by mouse
-  : To add nodes by mouse (right click to confirm)
-  : To add lines by mouse (right click to confirm)
-  : To add a polygon by mouse (right click to confirm)
-  : To move a node by mouse (right click to confirm)

 : Show the default 3D view. There is a dropdown menu below this button:



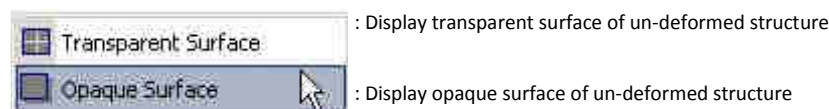

 : Display the transparent surface of un-deformed structure. There is a dropdown menu below this button:

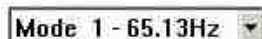

 : Render animation surface (for polygon elements) of not

 : Show the single view or quad view in the window

 : Select mode No. from the list (for mode shape animation)

 : Turn to next mode (for mode shape animation)

 : Turn to previous mode (for mode shape animation)

IMPORT GEOMETRY

You can import geometry information from UFF 15/82/2412 files and IGES files.

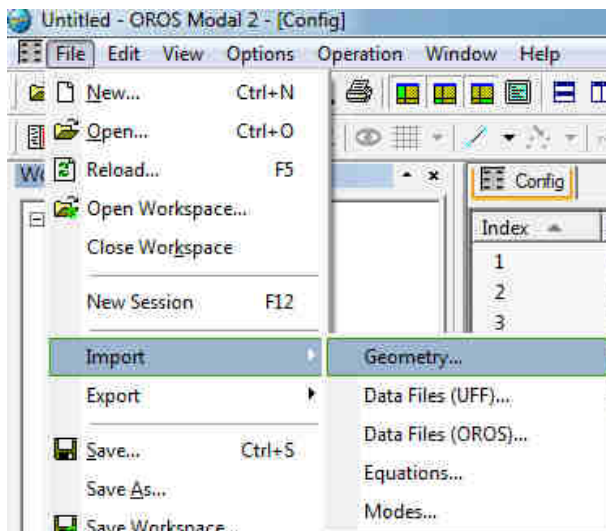

You can create geometry information in the Excel, and then copy and paste them to the "Config" view.

Index	::No. #	::Coord X	::Coord Y	::Coord Z	::Coord No.	::Memo
1	1	83.333	0.000	0.000	0	
2	2	166.670	0.000	0.000	0	
3	3	250.000	0.000	0.000	0	
4	4	72.169	-41.667	0.000	0	
5	5	144.340	-83.333	0.000	0	
6	6	216.510	-125.000	0.000	0	
7	7	41.667	-72.169	0.000	0	
8	8	83.333	-144.340	0.000	0	
9	9	125.000	-216.510	0.000	0	
10	10	0.000	-83.333	0.000	0	
11	11	0.000	-166.670	0.000	0	
12	12	0.000	-250.000	0.000	0	
13	13	-41.667	-72.169	0.000	0	
14	14	-83.333	-144.340	0.000	0	
15	15	-125.000	-216.510	0.000	0	
16	16	-72.169	-41.667	0.000	0	
17	17	-144.340	-83.333	0.000	0	
18	18	-216.510	-125.000	0.000	0	
19	19	-83.333	0.000	0.000	0	
20	20	-166.670	0.000	0.000	0	
21	21	-250.000	0.000	0.000	0	
22	22	-72.169	41.667	0.000	0	
23	23	-144.340	83.333	0.000	0	
24	24	-216.510	125.000	0.000	0	
25	25	-41.667	72.169	0.000	0	
26	26	-83.333	144.340	0.000	0	
27	27	-125.000	216.510	0.000	0	
28	28	0.000	83.333	0.000	0	

DATA ACQUISITION

Data acquisition is a critical step for modal analysis: without correct data, no exploitable results. Thanks to the direct acquisition implemented in Modal, enjoy the Teamwork analyzers power and accuracy with a dedicated interface for structural acquisition. The interface works with the different excitation modes: impact hammer, shaker, operating excitation.



Fig3: Generators outputs

To excite a large structure, up to 6 shakers per analyzers can receive signals from generators outputs. In order to fit the wide range of potential cases, the complete series of excitation signals from random, chirp, swept sine, stepped sine to normal modes can be generated.

For high channel count applications, Teamwork technology cascades several analyzers together to acquire simultaneously hundreds of channels. Teamwork instruments guarantee an efficient instrumentation thanks to the different possible configuration.

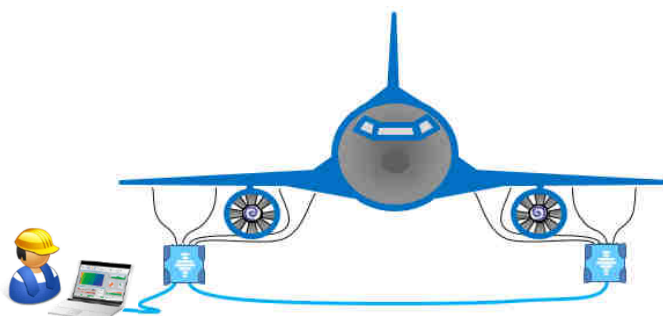

For example, this flexibility allows to highly reduce the cable length by distributing the instruments along the structure under test.

The direct data acquisition (DAQ) module is available in Modal, which enables you to complete a modal test easily and quickly.

Launch the DAQ by clicking the “Data Acquisition” item, shown as the following.

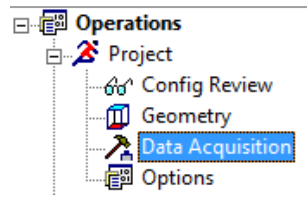

Then the geometry modeled in Modal will be transferred to DAQ automatically.

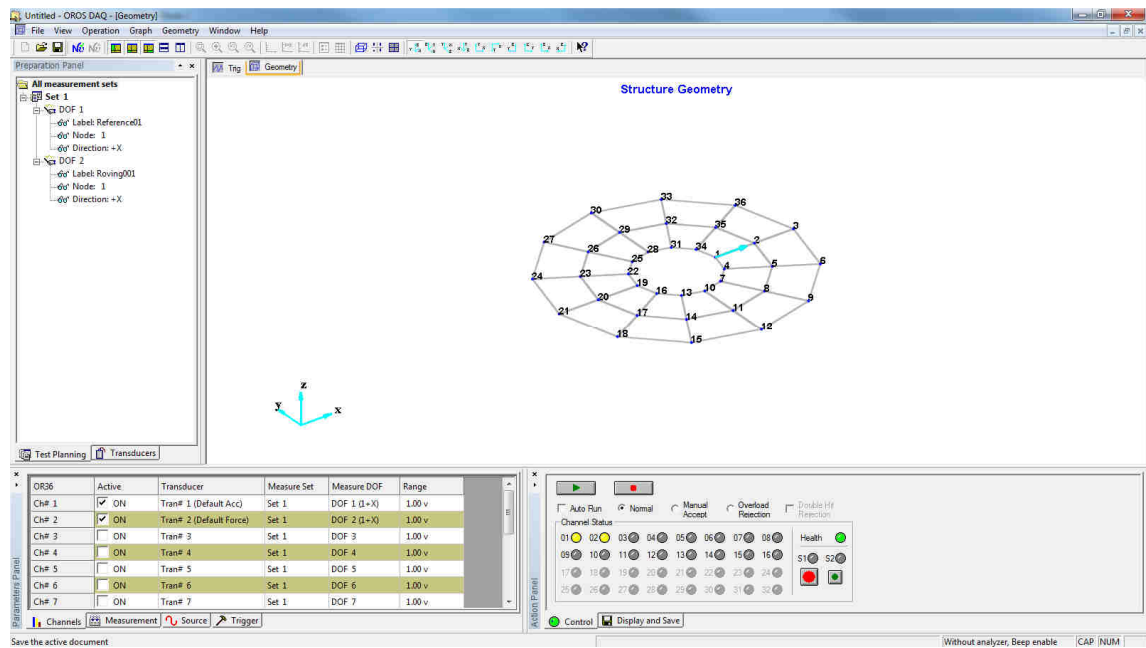

To perform a complete modal acquisition, follow the different steps described here.

TEST PLANNING

In the preparation panel, set the test planning.

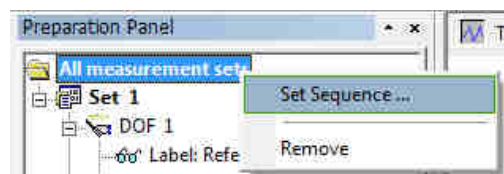

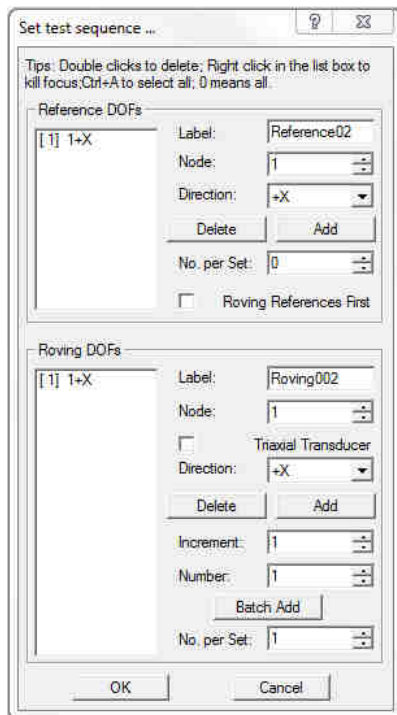

TRANSDUCERS DEFINITION

Set the transducer list in the 'Transducers' page of Preparation Pane. Note to select the correct transducer type and fill the correct sensitivity.

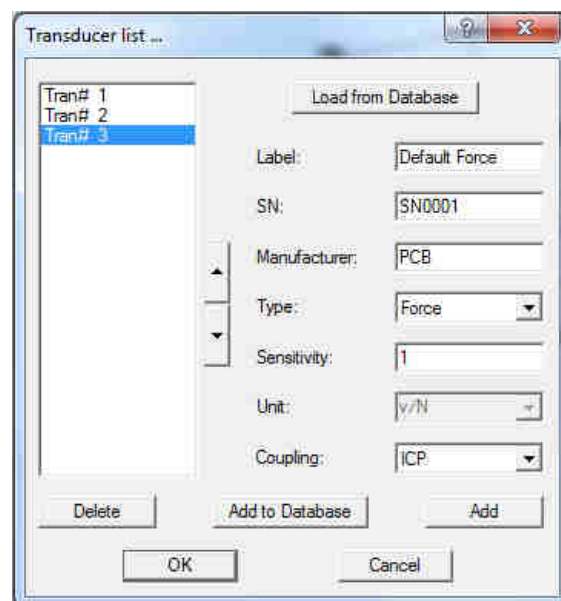
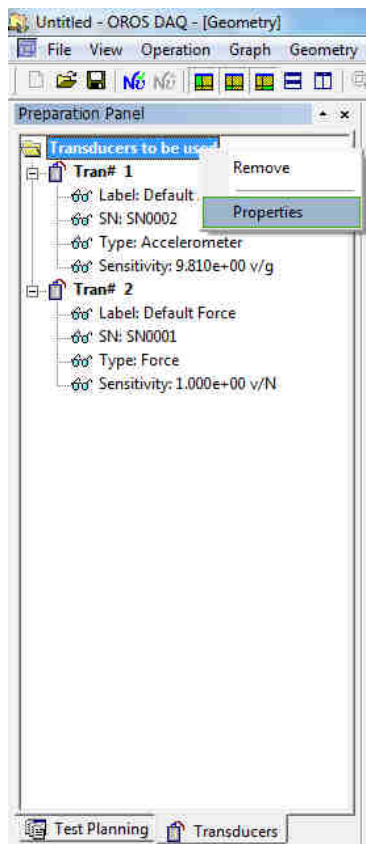

Check the different measurements directly on the geometry

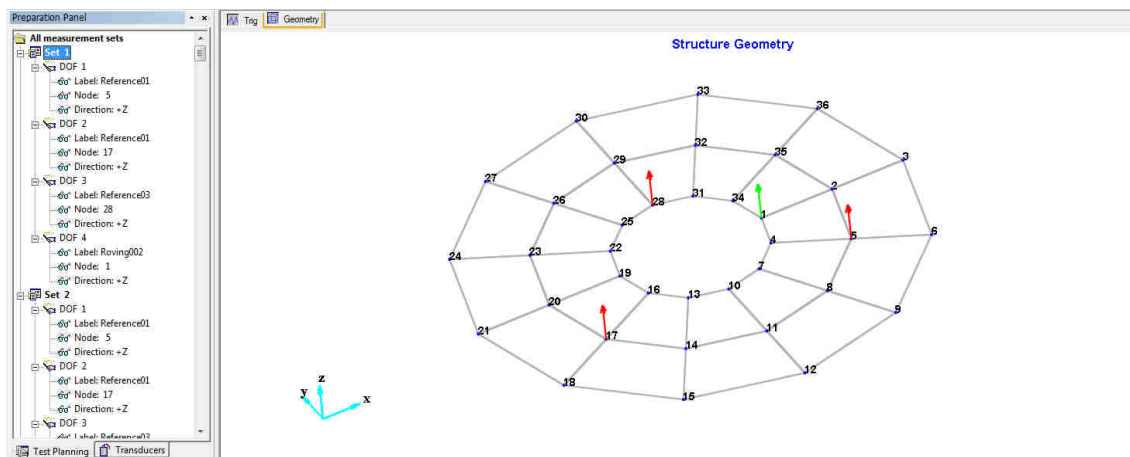

The references are displayed in red and the roving DOFs in green.

MEASUREMENT PARAMETERS SETUP

- Parameters Panel->Channel: set range for each active channel; match them to the corresponding measurement DOFs and transducers.

OR36	Active	Transducer	Measure Set	Measure DOF	Range
Ch# 1	<input checked="" type="checkbox"/> ON	Tran# 1 (Default Force)	Set 1	DOF 4 (1+Z)	1.00 v
Ch# 2	<input checked="" type="checkbox"/> ON	Tran# 2 (Default Acc)	Set 1	DOF 1 (5+Z)	1.00 v
Ch# 3	<input checked="" type="checkbox"/> ON	Tran# 3 (Default Acc)	Set 1	DOF 2 (17+Z)	1.00 v
Ch# 4	<input checked="" type="checkbox"/> ON	Tran# 4 (Default Acc)	Set 1	DOF 3 (28+Z)	1.00 v

- Parameters Panel->Measurement: set the frequency range, spectral lines, average number, and window type.

Freq Start	Freq Range	Spectral Lines	Sampling Time	Overlap	Average Type	Average No	Window Type
0 Hz	2000 Hz	401	200.00 ms	0 %	Linear	3	Uniform

- Parameters Panel->Trigger

Type	Channel	Slope	Level (%)	Level (v)	Delay (%)	Delay (s)
Input	Ch# 1	Rising	20 %	200.00 mv	-1 %	-2ms

DISPLAY ANS SAVE OPTIONS

Action Panel->Display and Save: set the data blocks you want to display and export. As the following graph, trigger block, FRF H1, and coherence will be displayed, trigger block and FRF H1 will be exported in the Binary UFF format. You can go to this data storage directory to check files by pressing button



ANALYZER CONNECTION

Click the button on the toolbar showed as the following to lunch NVGate and connect to it. During this process, you may be asked to operate the wizard of NVGate. You should confirm that the NVGate has been launched successfully before pressing the 'OK' button.





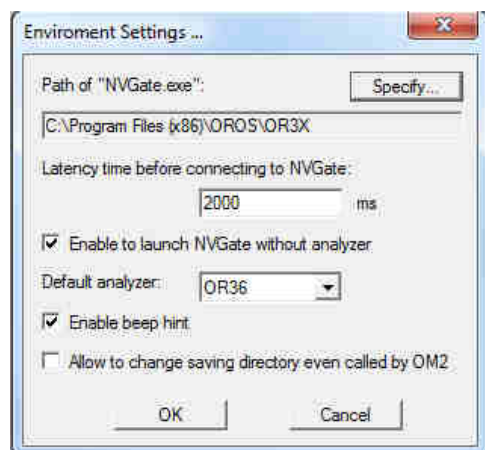

If necessary, you may need to set the environment parameters of DAQ by the menu of 'Operation'-'>Environment setting'. Please refer to the online help of DAQ for more details



Note that for acquisition with several synchronized analyzers, NVGate V10 minimum is required.

ACQUISITION CONTROL

Control Panel->Control: press  to begin the measurement,  to pause, and  to stop. If the 'Auto Run' option is checked, the measurement sets will be executed automatically one by one, you don't need to press the button  after one measurement set is finished. 'Normal', 'Manual Accept' and 'Overload Rejection' are different modes to accept the triggered data. You can also set 'Double Hit Rejection' to reject the continuous hits when performing a hammer impact test to get better measurement quality.

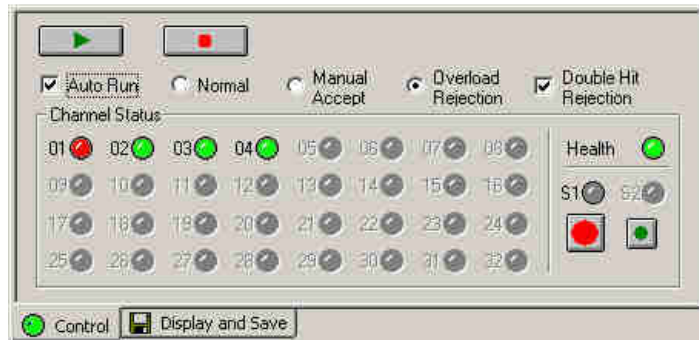

When the acquisition is completed, press the button of **Send FD Data** or **Send TD Data** to transfer the data to the Modal main interface and start the modal identification.

SIGNAL PROCESSING

Signal processing wizard is designed to set the parameters for signal processing. Many signal estimations can be realized, such as power spectrum estimation, multiple input multiple output frequency response function estimation, and coherence function estimation, and so on. Five steps should be performed in this wizard: [Estimation](#), [Detrending](#), [Decimation](#), [Fast Fourier Transform \(FFT\)](#), and [Windowing](#).

ESTIMATION

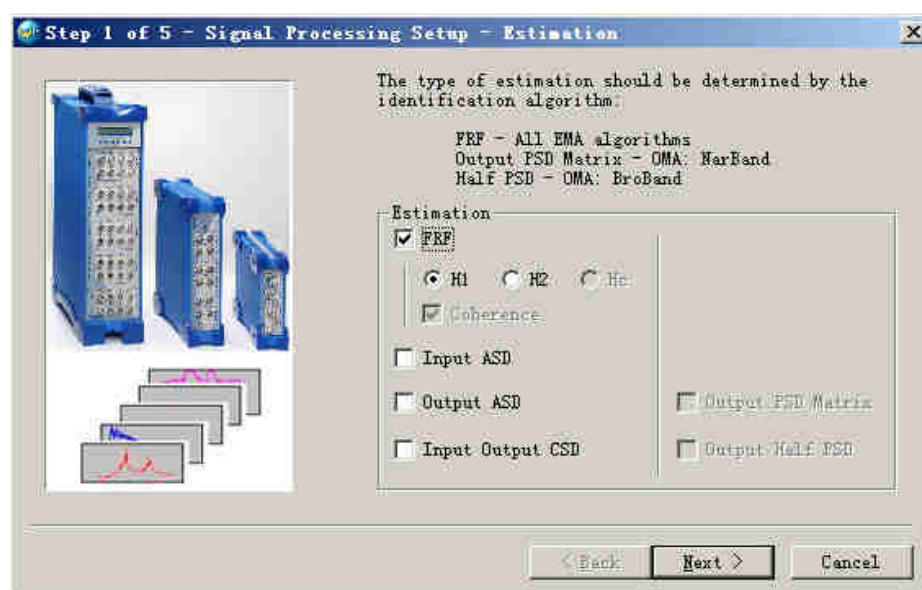

Various signal estimation process can be set in this page. You must estimate the 'FRF' if you want to perform modal parameters identification in the case of EMA. H1, H2 and Hc are three different methods for FRF estimation. Reference signal is needed for Hc method. You must estimate the 'Output PSD Matrix' (for OMA NarBand Full) or 'Output half PSD' (for OMA BroBand, OMA NarBand Half, and so on) if you want to perform modal parameters identification in the case of OMA.

The next step of signal processing wizard is [Detrending](#).

DETRENDING

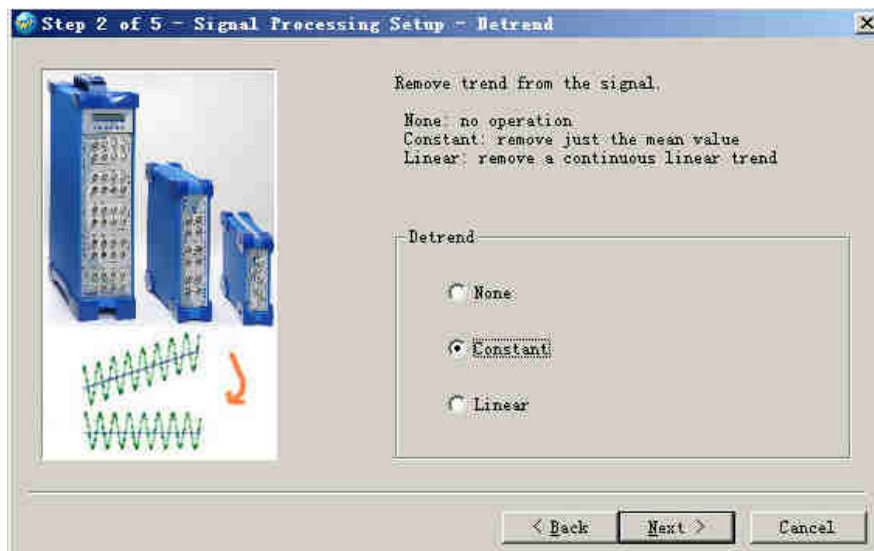

The purpose of detrending is to condition the time domain signals, remove their constant or linear trend. The previous step of signal processing wizard is [Estimation](#), and the next step is [Decimation](#).

DECIMATION

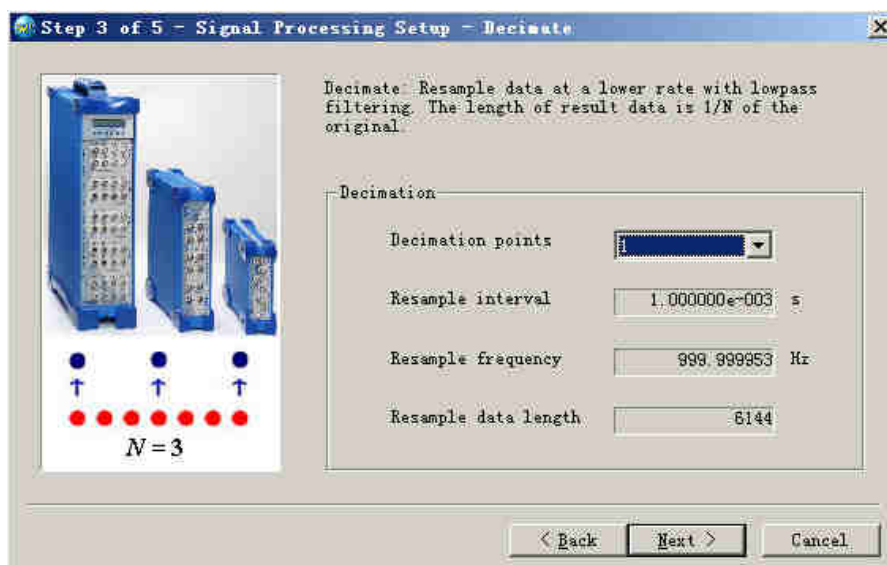

The purpose of decimation is to reduce the range of analysis frequency. For example, you are interest in the frequency range of 0~10 Hz, and the sampling frequency is 256 Hz, then you should set the decimation points to 10.

The basic principle of decimation is reserve part of points and removing the others: if the decimation points is N, the length of data will be 1/N of original data. To prevent the estimation from frequency aliasing, a low-pass filter is necessary in this process.

There are not any anti-aliasing filters in some low-cost data acquisition. It will greatly improve the quality of estimation for you to sample data with high frequency and then decimate them in Modal, partly compensating for the loss of anti-aliasing filters.

The previous step of signal processing wizard is [Detrending](#), and the next step is [setup of FFT](#).

SETUP OF FFT

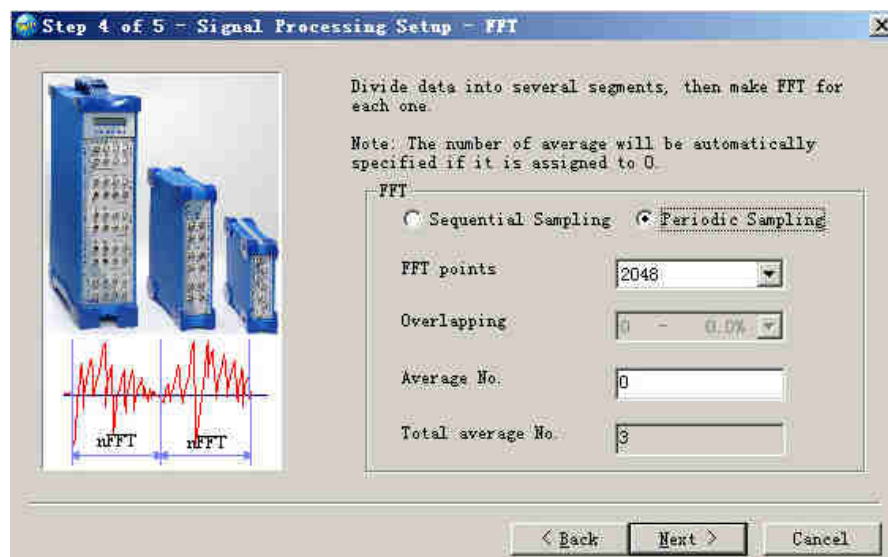

In this page, parameters for fast Fourier transform (FFT) will be set to transfer the time domain signals to frequency domain.

'Sequential Sampling' means that the data was sampled sequentially, without any pause. A typical instance is to sample data sequentially under random excitation. "Periodic Sampling" means that the data in the file was sampled periodically. A typical instance is to sample multiple frames of data in a hammer impact test, for the sake of performing average in the spectrum estimation. The practical significance of "Periodic Sampling" is the overlap percent is set to zero in FFT.

'FFT Points' specifies the length of each segment in the transform. The optional list will be confirmed by the software according to the length of imported data automatically. You can select one from this list. When the data points has less than 'FFT points', zeros will be padded, and truncated if it has more.

'Overlapping' specifies the percent of overlap between each segment. The purpose of overlap is to increase the times of average. For an example of 2048 data length and 1024 FFT points, if the overlap percent is set to 0, the original data can be divided into two segments for FFT (the first segment is from 1 to 1024, and the second part is from 1025 to 2048); When the overlap percent is set to 50%, the number of overlap points is 512, and the original data can be divided into three segments (the first segment is from 1 to 1024, and the second segment is from 513 to 1536, and the third segment is from 1025 to 2048).

'Average No.' specifies the number of average during the FFT calculation. Its default value is 0, which means the maximum possible average numbers. When the number specified by the user is larger than the maximum average number, it will be modified to the maximum average number automatically.

The previous step of signal processing wizard is [decimation](#), and the next step is [windowing](#).

WINDOWING

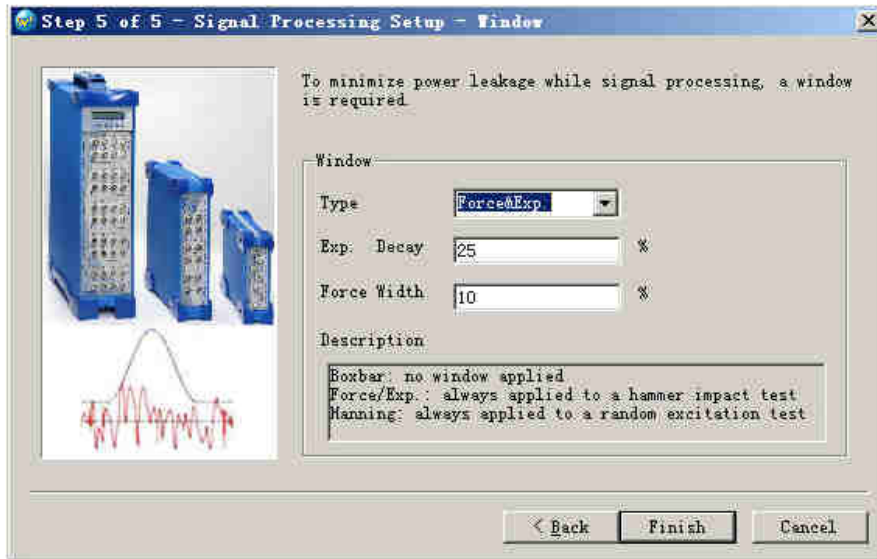

You can specify the windowing functions for the FFT in this page. The truncation and non-periodicity of signal will cause energy leakage and lead to alias error in the frequency domain. The main purpose of windowing is adding time weight functions to the signal to filter the non-periodicity part and reduce leakage. Six kind of window function such as [Boxcar](#), [Exponential](#), [Force & Exponential](#), [Hanning](#), [Hamming](#), [Flattop](#) is provided and can be employed for different cases.

BOXCAR

Boxcar window, called as Transient window also, has the shape of rectangle. It adds the same weight to all parts of the time history, i.e. no weight is added.

The Boxcar function has a value of 1 over its length and it only truncation the signal simply. It can be applied to the signal such as periodic (period random) and transient (Chirp, Burst Chirp) signal generally.

EXPONENTIAL

The shape of the exponential window is that of a decaying exponential. By assigning the time const, the exponential window damps the signal, ensuring that the signal fully decays by the end of the sample block.

Exponential function can be applied commonly to the measurement of light damping system.

The following equation defines the exponential window:

$$W(t) = e^{-\beta t}$$

Where β is a constant. In Modal, Td is defined as the exponential decay time over which exponential window function decays from 1 to 1/e, in this case, $\beta = 1/Td$. When applying exponential function to a signal, damping of the system will be increased and should be modified. The damping ratios and frequencies can be automatically modified in Modal if the exponential window is applied by the signal processing wizard. When the input data is FRFs which were estimated by applying exponential window, you should remember to specify the decay time (with unit of ms) in the configuration file.

Note: The value you should fill in this interface is not β , but the percentage of β constitutes to the sampling period.

FORCE & EXPONENTIAL

In a force window, the front part of the signal is preserved and the others are set to 0. The time length of the preserved signal is named force width. When Force & Exponential window is selected, exponential window is applied to both channels while force window is only applied to the reference channel.

Force window is very useful for the hammer impact test and it can wipe off the fluctuation of the force signal and greatly improve SNR (Signal Noise Ratio).

Note: You should fill the percentage of these values constitute to the sampling period as well.

HANNING

Hanning window is also named random window and has a shape similar to that of half a cycle of a cosine wave. It decays the start and end part of the signal and enforces the signal to become periodic.

It is a general-purpose window and is typically applied to the test excited by random noise.

HAMMING

Hamming window is similar to Hanning window and it can further decrease the side lobe.

FLATTOP

Namely cosine window, the flattop has the flatness power shape and the higher amplitude accuracy while poor frequency resolution.

The flattop window is most useful in accurately measuring the amplitude of specified frequency components such as filter characters.

This is the last step of the signal processing wizard, and the previous step is [setup of FFT](#). Press the 'Finish' button to confirm all the parameters set in the wizard, and you can begin to [signal processing](#) now.

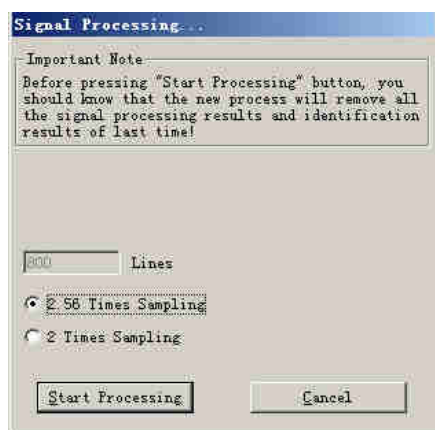

The sampling times can be set to 2.56 or 2. Usually in an EMA analysis it is set to 2.56, and in an OMA analysis it is set to 2. If the sampling times is 2.56, then the number of the spectral line will be $1/2.56$ of the FFT length, and the analysis frequency range will be $1/2.56$ of the sampling frequency. If the sampling times is 2, then the number of the spectral line will be half of the FFT length, and the analysis frequency range will be half of the sampling frequency.

After signal processing, the result data will be displayed under the directory of 'Data\Setup?\Estimate" in the 'Data' page of workspace short pane, such as FRF (frequency response function), COH (coherence function), Pxx (input auto power spectral density function), Pyy (output auto power spectral density function), Pxy (input and output cross power spectral density function), OPSD (output power spectral density matrix) and HPSD (half power spectral density function). Double click these items, and relevant curves or lists will be displayed in the main window.

If you want to do signal processing with other parameters, please run the wizard and process again. Before the new signal processing, all the result got from last signal processing will be refreshed or deleted automatically.

ODS & MODAL ANALYSIS

Modal can deal with Operating Deflection Shape (ODS) Analysis and two types of modal analysis: Experimental Modal Analysis (EMA, both input and output data are available) and Operational Modal Analysis (OMA, only output data are available).

You can find out how a machine or structure moves during its operation via ODS, which shows the overall dynamic characters of the structure or machine.

You can get the modal parameters of structures via EMA or OMA, by performing the following four steps: (1) Signal processing to get frequency response functions (for EMA) or output power spectrum matrices (for OMA); (2) Selecting an appropriate identification algorithm; (3) Doing modal identification; (4) Operating the identification results, such as viewing mode shapes, copying, and removing, and so on.

Almost all the algorithms begin with the Modal Indicator Function (MIF). Click here to familiarize its characteristics.

The following modules are available in Modal: TD ODS, FD ODS, EMA Narband (CMIF), EMA SelBand-SIMO (RFOP), EMA SelBand-MIMO 1 (FDPR), EMA SelBand MIMO 2 (RFPM), EMA BroBand (BBFD), OMA NarBand Full (FSDD), OMA NarBand Half (CMIF), and OMA BroBand (OBFD). A NarBand method means an algorithm performed in a narrow frequency band, who has the biggest advantage of simple and easy to use. You can identify the modes only by picking the peaks of MIF one by one. A SelBand method means an algorithm performed in one or several selected frequency bands. A BroBand method means an algorithm performed in a broad frequency band or even the full frequency band sometimes.

An effective tool Modal Assurance Criterion (MAC) is also provided to validate the result of modal identification.

MODAL ANALYSIS PROCESS ILLUSTRATION

SELECTING AN ALGORITHM

Before modal identification, you should select an appropriate algorithm according to the analysis type (EMA or OMA) and number of input (SIMO or MIMO). You can select the specified algorithm by mouse click on the corresponding item in the "Workspace" shortcut pane. A message will appear if you success in doing this.

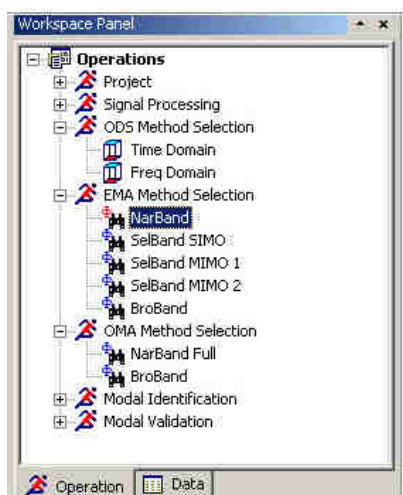

Another appropriate algorithm can be selected for necessary. And you can compare the results from different algorithms. If some selected algorithm is not fit for the current case, you will be prompted to select another one.

DOING MODAL IDENTIFICATION

It's recommended to employ the modal indicator function (MIF) for the modal identification in the frequency domain. The identification process varies according to different type of algorithms.

1. Narrow-Band Identification Algorithm

(1) Open the MIF curves interface by pressing the  button in the toolbar, and the following interface will appear:

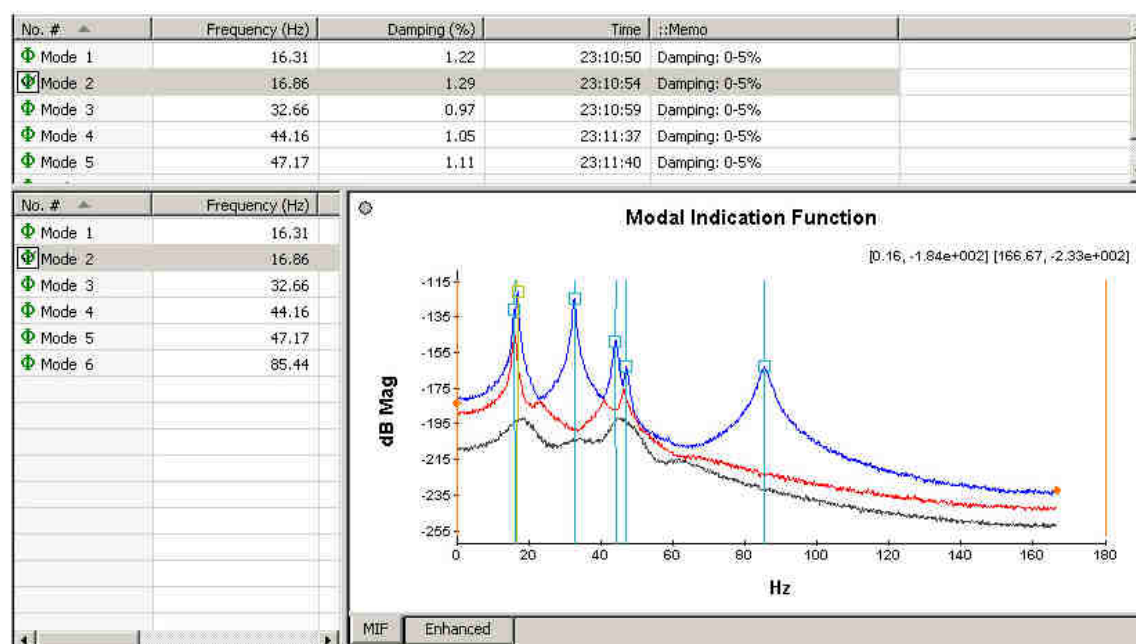



The interface consists of two mode list views and a tab window view ('MIF' tab and 'Enhanced' tab). The two mode list view is synchronous. You can adjust the separator lines to resize these views.

(2) Press the  button in the toolbar to begin the NarBand modal identification.

(3) Check the identified results and curve fitting of enhanced curves. All the identified modes will be shown in the two mode list views and output shortcut pane. You can check the relevant enhanced curves and its curve fitting in each setup for each mode. If ideal curve fitting hasn't been got, you can adjust the fitting band manually, and identify this mode again in the current setup by double clicks.

2. Select-Band Identification Algorithm

(1) Open the MIF curves interface by pressing the  button in the toolbar.

(2) Select the identification frequency band. Move the cursors by mouse or keyboard to the frequency point you want, then double click the mouse or press Enter key to select this band. As a result, a tag like "[]" appears to indicate this selected band. The data in this band will be used for modal identification. Multiple selected bands for the identification are allowed in Modal, and all the data in these bands will be used to identify modal parameters. To delete the latest selected band, you can use the  button in

the toolbar, or by the mouse's middle click. To delete all the selected bands, you can use the  button in the toolbar, or by the mouse's middle double clicks.

(3) Specify the modal order in the selected bands. MIF plot can be used to indicate the modes existence efficiently. A peak in this plot means a mode. For example, in the selected band of the following figure, four modes are detected, including two heavily closed modes.

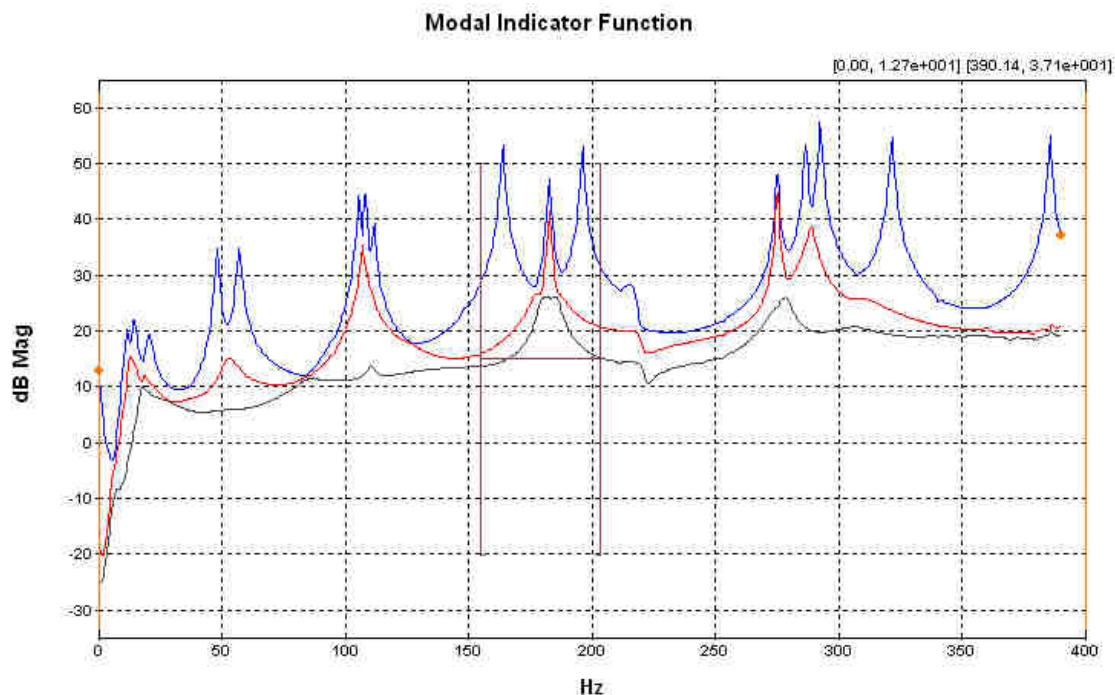

(4) Press the  button in the toolbar to begin modal identification with selected algorithm.

(5) Check the results. The synthesized FRF/HPSD curves will appear in the main window after identification, and the result will be shown in the output shortcut pane. At the same time, an item corresponding to the selected identification algorithm will appear under the directory of 'Data\Setup1\Mode' in the workspace shortcut pane.

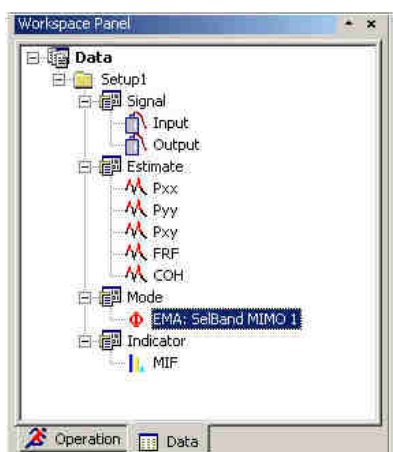

Double click on this item will show the identified mode list.

No. #	Frequency (Hz)	Damping (%)	Modal A	Time	Memo
Mode 1	65.13	0.94	1.31e+01 + 1.98e+02i	10:26:13	Damping: 0-5%
Mode 2	89.16	0.20	-1.42e+02 + 1.40e+02i	10:26:13	Damping: 0-5%
Mode 3	135.32	0.51	-1.16e+01 + 3.39e+02i	10:26:24	Damping: 0-5%
Mode 4	183.02	0.31	-2.76e+01 + 5.52e+02i	10:26:32	Damping: 0-5%
Mode 5	221.20	0.20	-1.90e+01 + 6.01e+02i	10:26:43	Damping: 0-5%
Mode 6	252.88	0.03	-7.95e+01 + 5.21e+02i	10:26:53	Damping: 0-5%
Mode 7	327.98	0.20	-6.92e+01 + 1.05e+03i	10:27:01	Damping: 0-5%
Mode 8	457.48	0.26	-2.24e+01 + 1.04e+03i	10:27:08	Damping: 0-5%
Mode 9	523.08	0.29	-1.42e+01 + 1.29e+03i	10:27:17	Damping: 0-5%
Mode 10	539.82	0.11	-2.20e+02 + 1.30e+03i	10:27:17	Damping: 0-5%
Mode 11	673.38	0.47	-2.32e+02 + 1.68e+03i	10:27:28	Damping: 0-5%
Mode 12	684.54	0.59	-7.66e+01 + 1.70e+03i	10:27:28	Damping: 0-5%
Mode 13	742.68	0.17	-2.01e+02 + 1.92e+03i	10:27:37	Damping: 0-5%

3. Broad-Band Identification Algorithm

The process of Broad-Band algorithms is almost the same with Select-Band algorithms, only that broader or even full frequency band can be set for the Broad-Band identification.

OPERATING THE RESULTS

Detailed information on identified modal frequencies, damping ratios, identification time, if structural mode are displayed in the mode list view. You can sort the modes ascending or descending according to the specified keyword by clicking on this column header. Also you can do many other operations by the toolbar or right click popup menu, such as deleting modes, copying modes, viewing the mode shapes, exporting the modes, and so on.



You can also double click on the icon of 'Φ' in the front of each row to view the mode shape animations. The mode shape animations are an import criterion of modal identification.

MODAL INDICATOR FUNCTION (MIF)

A very important step of modal identification is to determine how many modes are contained in a selected frequency band. MIF plot is a very good tool to achieve this, indicating the modes efficiently.

MIF can be employed in not only EMA, but also OMA. The number of MIFs equals the number of excitations or references. The MIFs consist of the singular values of frequency response function matrix (FRF), output power spectral density matrix (OPSD), or half power spectral density matrix (HPSD).

By the powerful singular value decomposition, the real signal space is separated from the noise space. Therefore, the MIFs exhibit the modes effectively. A peak in the MIFs plot usually indicate the existence of a structural mode, and two peaks at a same frequency point means the existence of two repeated modes. Moreover, the magnitude of the MIFs always implies the strength of a mode.

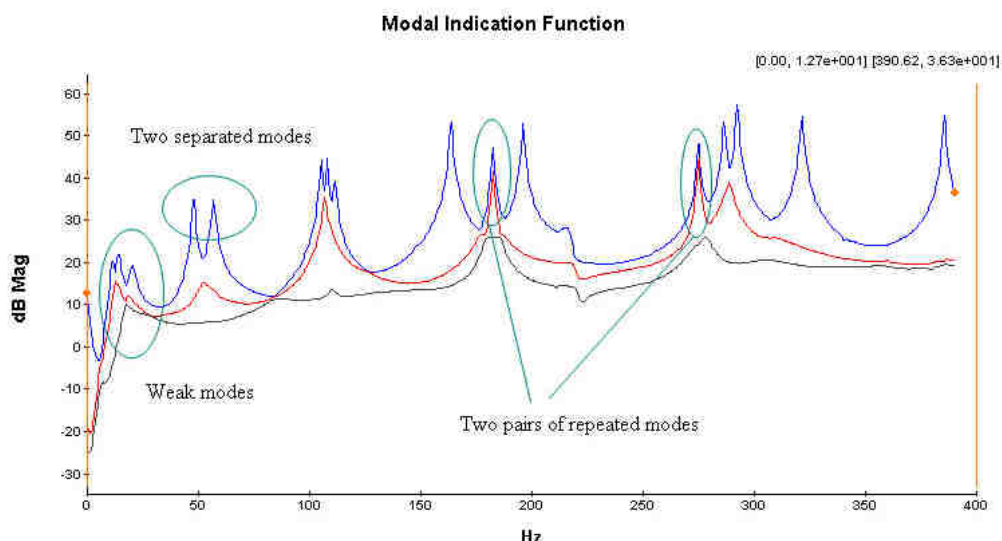

Sometimes we should note the cross modes, for example

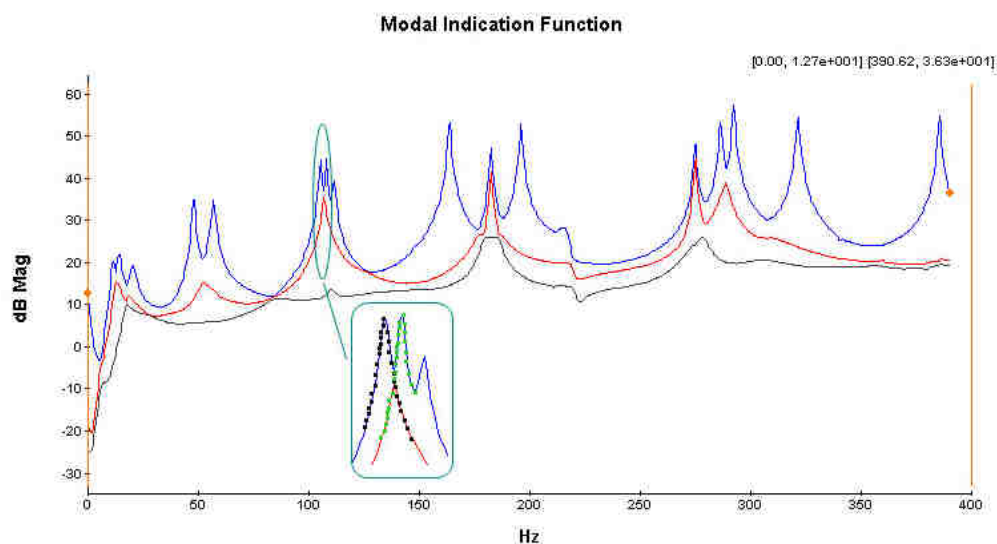

As showed in the above figure, the peak in the second MIF curve doesn't indicate a mode. It's formed by the cross of two modes.

OPERATING DEFLECTION SHAPE

TIME DOMAIN ODS

With Modal, you can animate time domain ODS directly from multi-channel data that was acquired spatially from a machine or structure. This is done by sweeping a cursor through a set of time histories. You can stop the animation, back it up, and play it forward to observe in slow motion vibration phenomena that may have taken place very quickly.

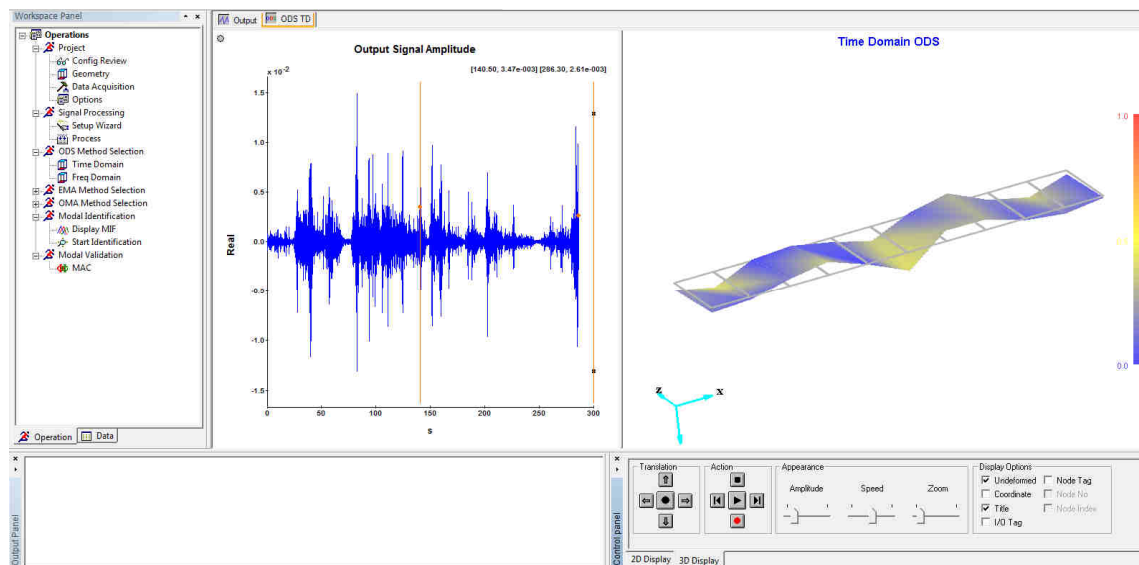

FREQUENCY DOMAIN ODS

With Modal, you can animate frequency domain ODS directly from data that was acquired spatially from a machine or structure. This is done by sweeping a cursor through a set of frequency domain measurements, or dwelling at a specific frequency. A FD ODS allows you to see how a structure behaves at a single frequency.

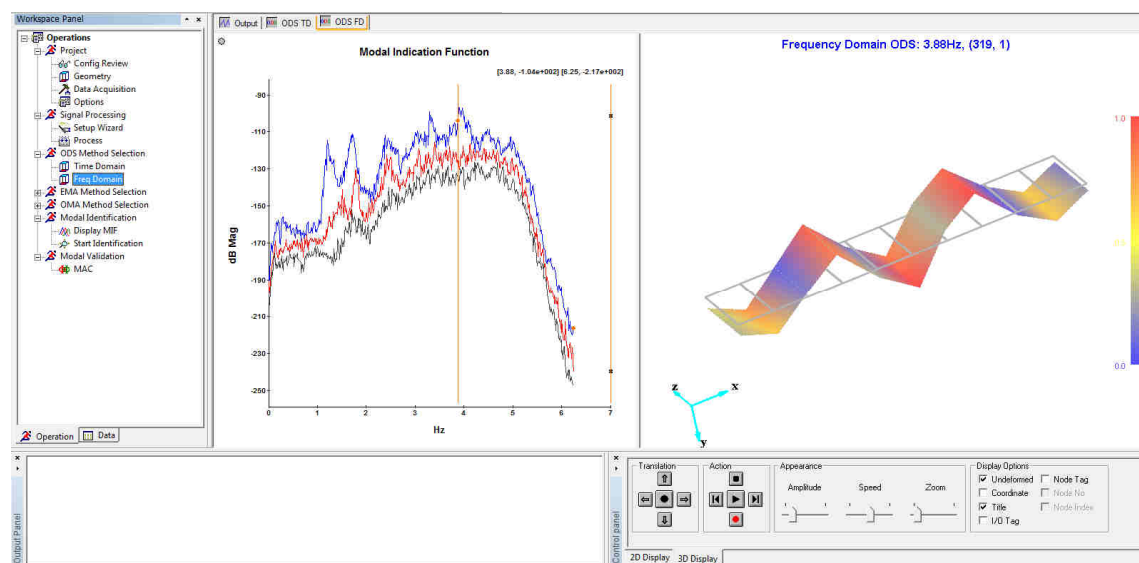

MODAL ANALYSIS

MODAL IDENTIFICATION METHODS

Modal analysis can be conducted via artificial excitation, e.g. shaker or instrument hammer excitation, and input force and output responses are measured. That is normally called an Experimental Modal Analysis (EMA). Modal analysis can be also accomplished during operational conditions of a mechanical

structure via responses measurements due to ambient or natural excitation, or other excitation but without input force measurements. This is called as Operational Modal Analysis (OMA).

Modal identification algorithms can generally be divided into 2 categories: Time domain (TD) techniques and frequency domain (FD) techniques. TD modal identification has the advantage of estimation of all the modes in the frequency band of interests at once. However, all the TD modal identification algorithms have common unfavorable feature, difficulty to distinguish physical (structural) modes from computational (noise) modes. For application to real-world structure, to locate structural modes reliably is the most important task of a modal analysis. This is why only FD techniques are implemented in OM2.

EMA	OMA
<p>EMA approach can be divided into three levels based on Single Input Single Output (SISO), Single Input Multiple Outputs (SIMO), Multiple Input Multiple Outputs (MIMO).</p> <p>Modal is born in MIMO. However, SIMO algorithm is also implemented for preliminary application.</p> <p>MIMO EMA has important advantages: not only consistent results can be obtained, but close spaced and even repeated modes can be identified.</p> <p>A modal Indication function (MIF) is calculated via Singular-Value-Decomposition (SVD) of the frequency Response Functions.</p>	<p>OMA is a powerful tool to extract dynamic characteristics of real world structure from output-only measurements during operational conditions. The output response can be generated by ambient or natural excitation as well as artificial broadband excitation (but without input force measurements).</p> <p>A modal Indication function (MIF) is calculated via Singular-Value-Decomposition of Power Spectrum Density (PSD) matrix or Half Power Spectrum Density (HPSD) matrix.</p>

OMA Narband Full

<p>Narrow-band operational modal identification algorithm in frequency domain.</p> <ul style="list-style-type: none"> • Distinguishes structural modes from noise modes much easier compare to TD OMA. • Based on modal decomposition of Power Spectrum Density (PSD) matrix. • Identifies one mode at a time. • Can easily deal with closely spaced or even repeated modes of real word mechanical structures. • Easy-to-use. • An assumption that singular vector, i.e. mode shapes vector, are orthogonal is made. However, even with this approximation, the modal parameters identified still have enough accuracy to meet engineering need.

EMA Narband

Narrow-band MIMO modal identification algorithm.

- Identifies one mode at a time.
- Can easily deal with closely spaced or even repeated modes of real world mechanical structures.
- Easy to use.
- As typical spatial domain decomposition technique enough output measurements are required.
- An assumption that singular vector, i.e. mode shapes vector, are orthogonal is made. However, even with this approximation, the modal parameters identified still have enough accuracy to meet engineering need.

OMA Narband Half

Narrow-band MIMO modal identification algorithm.

- Based on modal decomposition of Half Power Spectrum Density (HPSD) matrix.
- Identifies one mode at a time.
- Can easily deal with closely spaced or even repeated modes of real world mechanical structures.
- Easy to use.
- As typical spatial domain decomposition technique enough output measurements are required.
- An assumption that singular vector, i.e. mode shapes vector, are orthogonal is made. However, even with this approximation, the modal parameters identified still have enough accuracy to meet engineering need.

EMA Selband SIMO

Selected-band SIMO modal identification technique, suitable for the modal test with only one excitation or one reference, e.g., a single shaker or single reference for impact tests.

- Identifies a few modes at a time at user-selected frequency bandwidth.
- Based on Rational Fraction Polynomial formulation of frequency response function (FRF). To improve numerical performance, orthogonal polynomial is adopted instead of power polynomial in traditional FRF representation.
- Can be applied in modal testing with a few response measurements.

EMA Selband MIMO1

Selected-band MIMO modal identification technique.

- Identifies a few modes at a time at user-selected frequency bandwidth.
- Can easily deal with closely spaced or even repeated modes of real-world complex mechanical structures.
- A rank chart is displayed to be sure of

the number of modes within the frequency band.

- All modal parameters within the frequency band will be automatically identified.
- FRF curve-fitting, i.e. comparison between synthesized FRFs based on identified modal parameters and measured FRFs is applied for validation.
- Use Singular-Value Decomposition (SVD) of FRF data for distinguish structural modes from noise modes, and Principle Component Analysis (PCA) for data condensation.
- Easy to use.
- Normally the number of measurements should be larger than the number of modes.

EMA Selband MIMO2

Selected-band MIMO modal identification technique.

- Identifies a few modes at a time at user-selected frequency bandwidth.
- Can easily deal with closely spaced or even repeated modes of real-world mechanical structures.
- Based on Rational Fraction Polynomial formulation of frequency response function (FRF). To improve numerical performance, orthogonal polynomial is adopted instead of power polynomial in traditional FRF representation.
- It would be better to limit the number of references DOFs of the FRF matrix, e.g. less than three.
- Can be applied in modal testing with a few response measurements.

EMA Broadband

Broad-band MIMO modal identification technique.

- Identifies all modes in a broad frequency band or even in the full frequency band.
- Can easily deal with closely spaced or even repeated modes of real-world mechanical structures.
- Can deal with heavily damped modes.
- Can produce clear frequency

OMA Broadband

Broad-band operational modal identification technique.

- Based on the Half PSD estimated from output responses.
- Identifies all modes in a broad frequency band or even in the full frequency band.
- Can easily deal with closely spaced or even repeated modes of real-world mechanical structures.

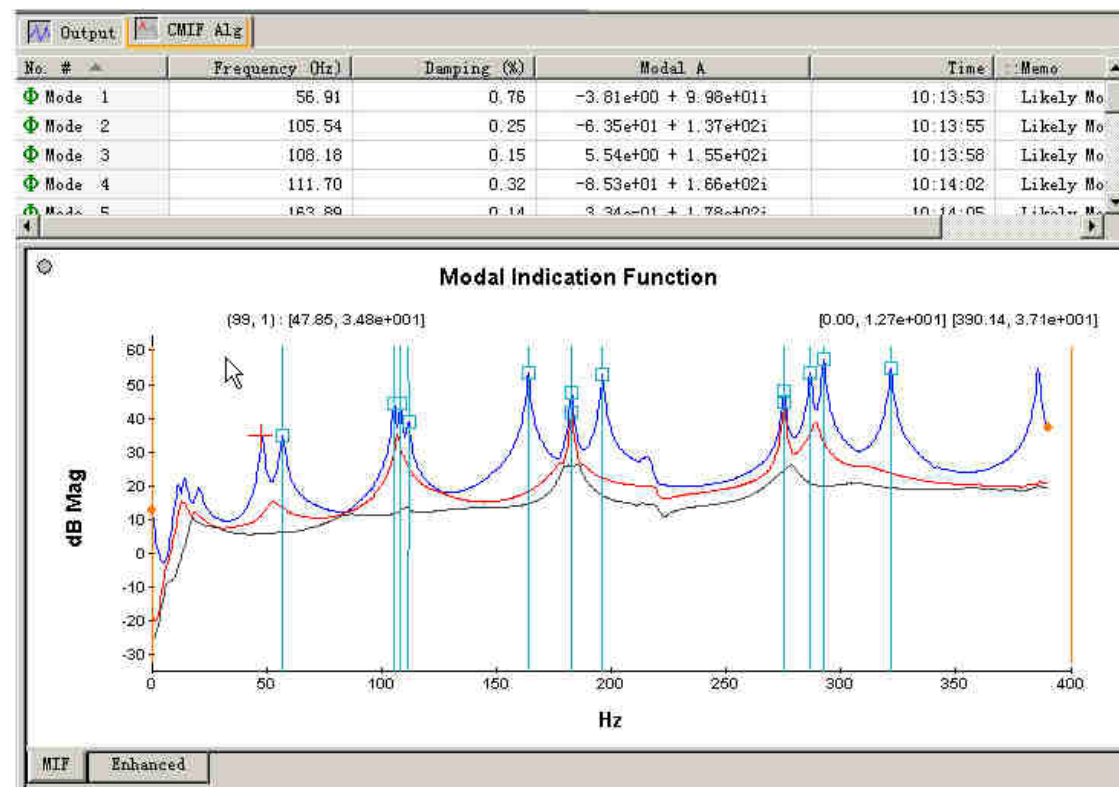

stabilization chart.

- Selects the structural poles automatically.
- It is recommended to identify the rigid body modes along.
- Can be applied in modal testing with a few response measurements.
- Can deal with heavily damped modes.
- Can produce clear frequency stabilization chart.
- Selects the structural poles automatically.
- It is recommended to identify the rigid body modes along.

NARBAND (CMIF)

Complex Mode Indicator Function (CMIF), is a narrow band modal identification algorithm in the frequency domain. CMIF an easy-to-use method. You should use it as the following steps:

SELECTING A PEAK

Press the button  in the toolbar, and click the MIF plot to activate it. A red cross marker '+' will appear, who is able to find the local peak automatically. The index and coordinate value of the marker are shown in the top left corner of MIF graph. In the figure below, (99,1):[47.85,3.48e+001] means that the cross cursor is now at the 99th point of the first MIF curve, and the coordinate is (47.85, 34.8).

AUTO IDENTIFICATION

After selecting the peak, you should double click to finish this identification. The identified results will be shown in the MIF plot, mode list and output shortcut pane. Each identified mode will be marked with a shape symbol. Its middle pane indicates the position of peak, and the line points to the identified frequency. The mode selected in the mode list will be marked yellow in the MIF plot while the others are blue.

CHECKING CURVE FITTING AND REFITTING

You can check the quality of curve fitting by selecting some mode in the mode list and then turning to the 'Enhanced' tab page. Seen from below, the blue one is the enhanced FRF curve, and the red one is its fitting curve. Sometimes the identification result is not good because of the automatically selected band is not the best. Thus you can move the two cursors to select a better band, then **double click** to identify this mode again.

SELBAND SIMO (RFOP)

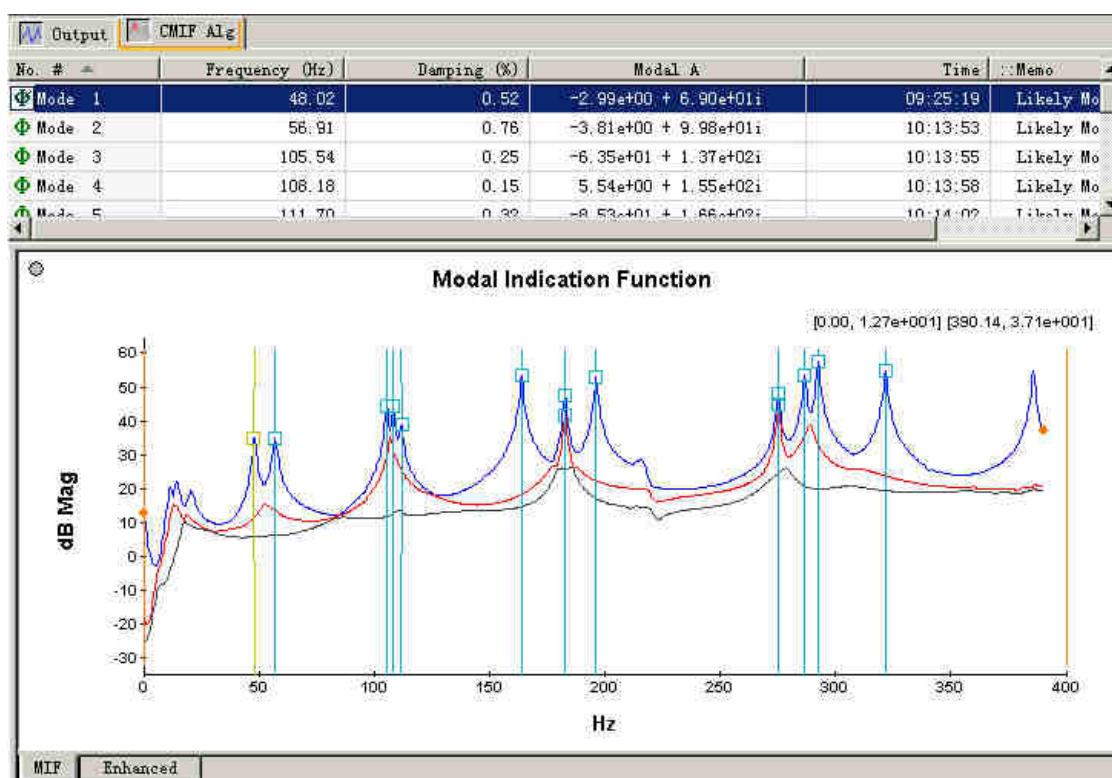

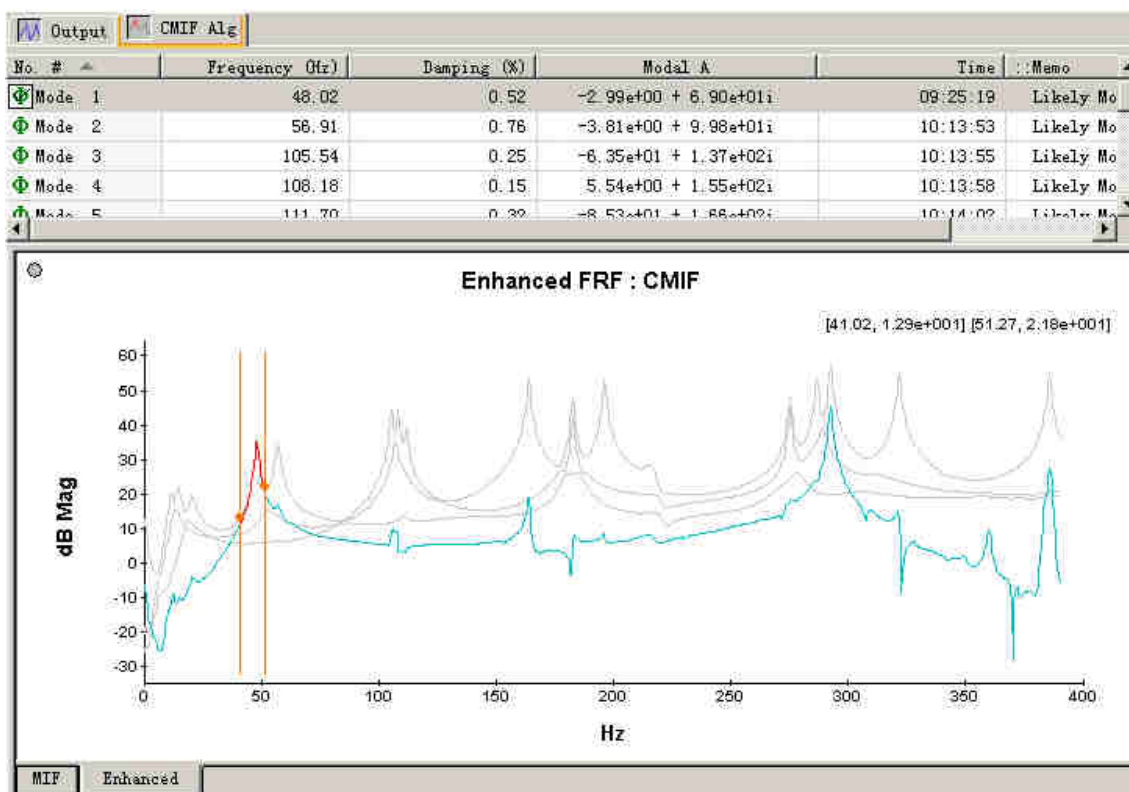

Rational Fraction Orthogonal Polynomials (RFOP), is an SIMO modal identification algorithm in the frequency domain. It is suitable for cases with only one excitation or one reference. RFOP can fit the FRFs or HPSDs in a fairly broad frequency band.

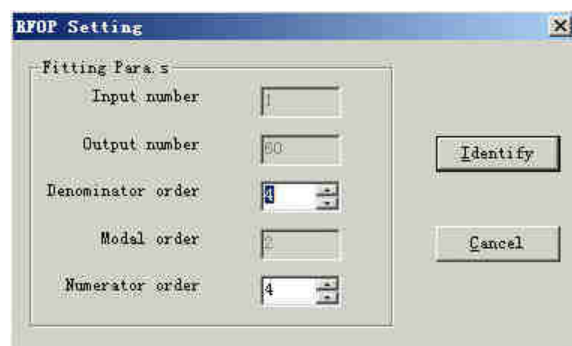

Each parameter is defined as the following :

INPUT NUMBER

Number of excitations or references. It is automatically displayed by the software, and can only be 1 in the RFOP algorithm.

OUTPUT NUMBER

Number of excitations or non-references. It is automatically displayed by the software.

DENOMINATOR ORDER

Rational fraction math model is used in the RFOP algorithm, and the order of denominator is twice of the modal order in the selected frequency band. Generally you can confirm the modal order by the MIF plot. In some cases, the modal order should be increased properly to hold the noisy modes, and the noise modes can be deleted by the criterion on damping ratios and mode shapes.

MODAL ORDER

This parameter varies with the denominator order you set. You should ensure that this value equal or larger than the real modal order in the selected frequency band.

NUMERATOR ORDER

This parameter varies with the denominator order you set, and keeping equal to it. You are allowed to set this value individually to be larger than the denominator order, for the sake of compensating for the out-band modes.

SELBAND MIMO1

Frequency Domain Poly-reference (FDPR), is a MIMO modal identification algorithm in the frequency domain. It is suitable for cases with multiple excitations or multiple references. FDPR usually fits the FRFs or HPSDs in a narrow frequency band. The outstanding advantage of FDPR is its highly easy-to-use.

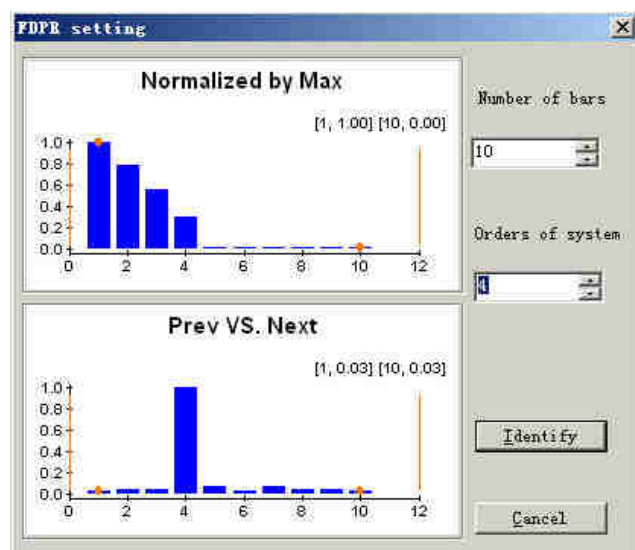

Besides the MIF plot, two another bar graphs are provided for you to confirm the modal order in the selected frequency band according to the bars' height. The upper graph shows the relative height of each mode, and it indicates the first four modes are greater than others. The lower graph shows the ratio of previous mode vs. next mode. You will find the fourth one is extremely high. It means that there are 4 structural modes, and the rest are 'noisy modes". So, here you should specify the system order to 4.

Each parameter is defined as the following :

NUMBER OF BARS

Number of bars shown in the graph, default as 10. The minimum value of this parameter is 2, and the maximum value is the output number of FRFs. You can change this value to view the bars more clearly.

ORDER OF SYSTEM

Modal order in the selected frequency band. Generally a fairly good value will be automatically set according to the practice. You are also allowed to change this value to get better result.

EMA SELBAND MIMO2

Rational Fraction Orthogonal Polynomials for MIMO (RFPM), is a MIMO modal identification algorithm in the frequency domain. It is suitable for cases with multiple excitations or multiple references. RFPM can fit the FRFs or HPSDs in a fairly broad frequency band.

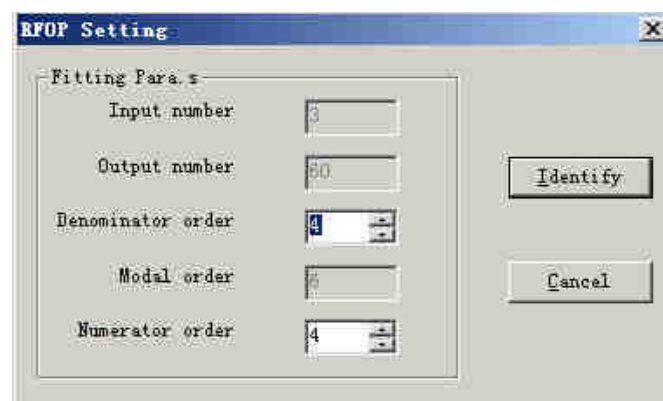

Each parameter is defined as the following :

INPUT NUMBER

Number of excitations or references. It is automatically displayed by the software.

OUTPUT NUMBER

Number of excitations or non-references. It is automatically displayed by the software.

DENOMINATOR ORDER

Matrix form fractional fraction math model is used in the RFPM algorithm, and the order of denominator is related with the modal order in the selected frequency band. Generally you can confirm the modal order by the MIF plot. The product of denominator order and input number should be larger than twice of the modal order. When the product of denominator order and input number is larger than the twice of the modal order, noisy modes will be identified, which can be deleted by the criterion on damping ratios and mode shapes.

MODAL ORDER

This parameter varies with the denominator order you set. You should ensure that this value equal or larger than the real modal order in the selected frequency band.

NUMERATOR ORDER

This parameter varies with the denominator order you set, and keeping equal to it. You are allowed to set this value individually to be larger than the denominator order, for the sake of compensating for the out-band modes.

EMA BROADBAND (BBFD)

The BroBand modal identification module is based on the algorithm of Polyreference Least Squares Complex Frequency (p-LSCF), developed in 2003. p-LSCF is a frequency MIMO modal identification algorithm which has superior performance compared to most time domain MIMO techniques, such as Polyreference Least Squares Complex Exponential (PRCE or LSCE), Extended Ibrahim Time Domain (EITD), and Eigensystem Realization Algorithm(ERA). BroBand EMA makes use of measured Frequency Response Function (FRF) as source data.

FEATURES/ADVANTAGES OF EMA BROBAND

EMA BroBand does not suffer from numerical problems, i.e. ill-conditioning problem in computing poles of the system in broadband as most frequency domain modal identification algorithm, e.g. Rational Fraction Orthogonal Polynomial (RFOP) and Frequency Domain Polyreference (FDPR), encountered. Compared to SelBand techniques, BroBand can then be applied to identify all the modes in a wide, including full, frequency band of interest at one time.

Compared to most time domain modal identification techniques, such as well know Polyreference (or Least Squares) Complex Exponential (PRCE, or LSCE) technique, :BroBand yields extremely clear stability diagram, making it much easier to select structural modes, or the physical poles, from which modal frequencies and damping ratios can be readily obtained.

The BroBand modular in OM2 has the feature of automatic modal sorting capability, i.e. BroBand can automatically distinguish structural modes from “noise” modes, or real modes from spurious modes.

MAIN PROCEDURES FOR EMA BROBAND

Major procedures for modal identification with EMA Broband are as follows:

1. Select a frequency band

The EMA Broband can be used to identify all modes in a broad frequency band, including full band. However, frequency band selection may be advantageous and is suggested in the cases as:

- In the “soft” suspension of test article to simulate free-free boundary condition, so called “rigid-body modes” are sometime weakly excited in low frequency range. In this case, frequency band

selection excluding this low frequency range is suggested for identification of flexible structural modes. The “rigid-body modes” can also be obtained with selection of corresponding low frequency band.

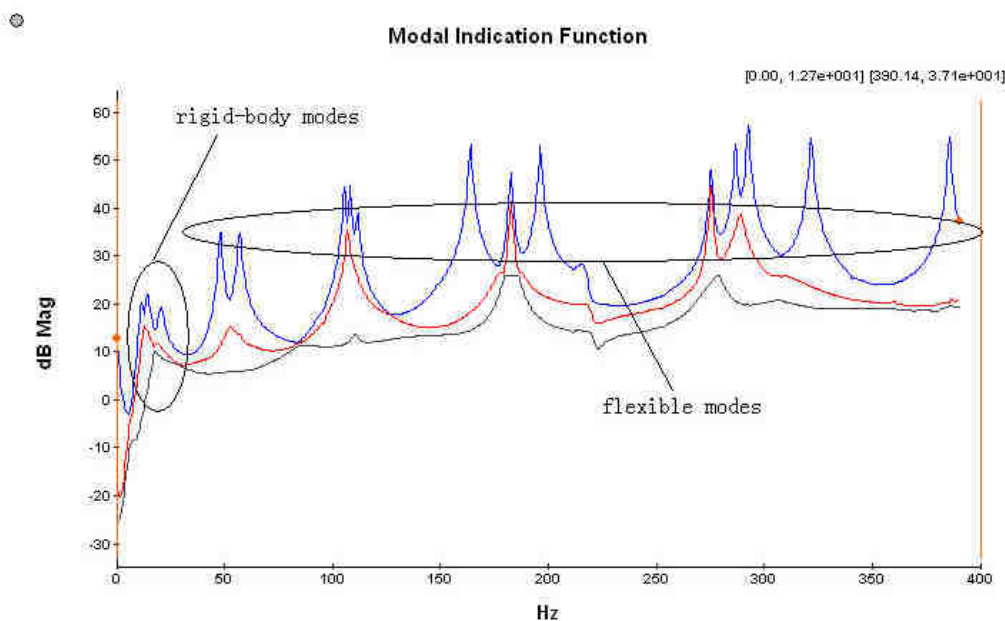

- A structure under testing sometimes shows “strong mode” or “global modes” in specific frequency band, and “weak modes”, or “local modes” in other frequency band. These “strong/global modes” and “weak/local modes” can be easily observed from Modal Indication Function (MIF) plot based on height of the MIF peaks. In this case, it is suggested to divide the full band into few sub-band which cover “strong/global modes” and “weak/local modes”, respectively.

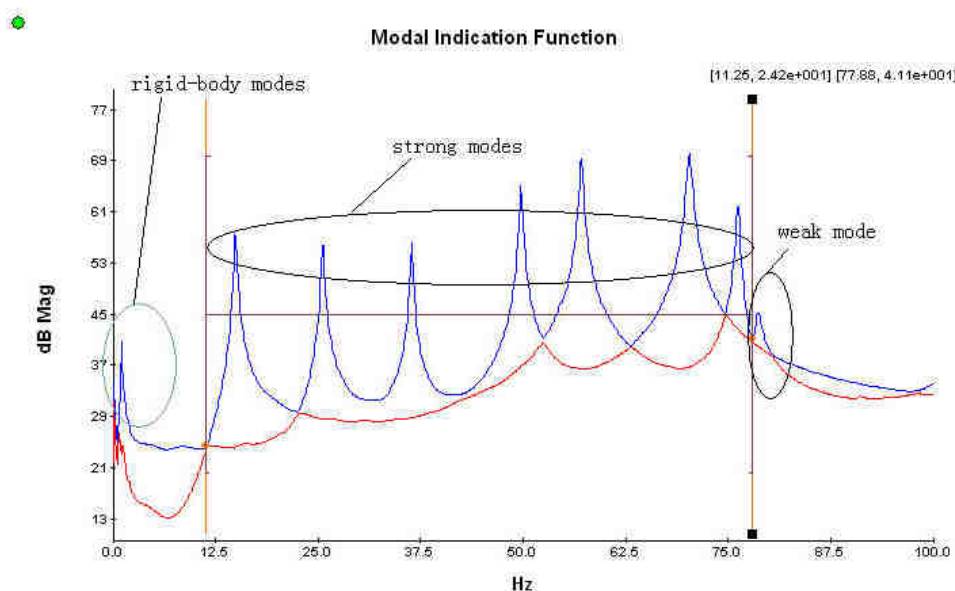

- It is suggested to start the frequency band from a valley of the MIF plots, and end the band at a valley too. According to our experience, such a frequency band can yield better result.

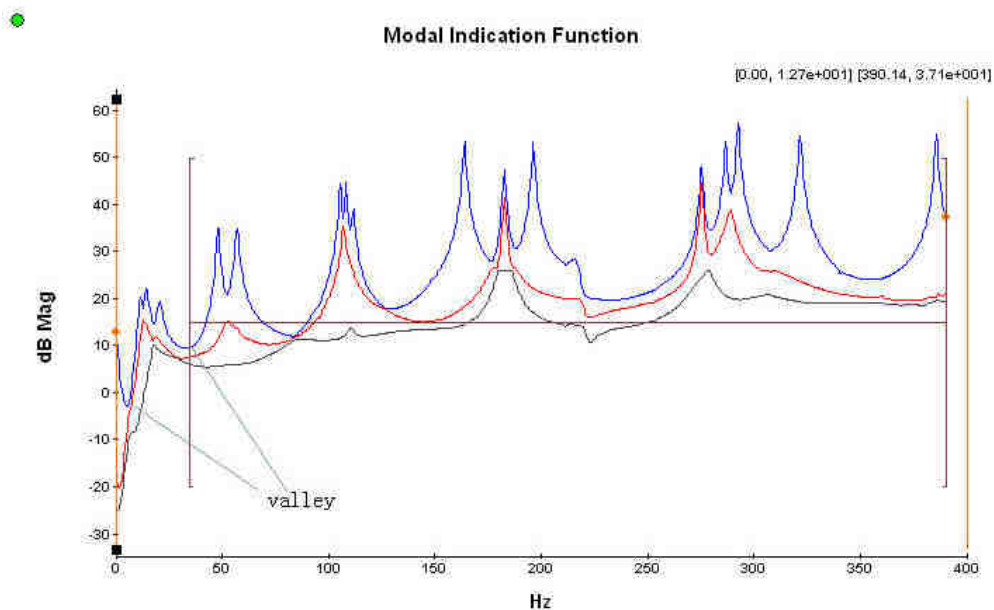

2. Start Identification

Press the button of "Start Identification"  in the toolbar to start modal identification.

3. Modal Order determination

Preliminary determination of the number of modes in the selected frequency band according to the MIF plot, and fill it in the edit box of "Preset Modes No." Then the BroBand software will calculate a default "minimum order" according to this number. The relationship between "Preset Modes No." and "Minimum Order" is: $\text{minimum order} = (\text{preset modes No.}) * N_i / 2$, where N_i means the number of input.

Change the number of "Order Span" if necessary. The BroBand software will estimate the poles with a range of system order from "Minimum Order" to "Maximum Order", where $\text{Maximum order} = \text{Minimum order} + \text{Order Span} - 1$. The default order span is 12.

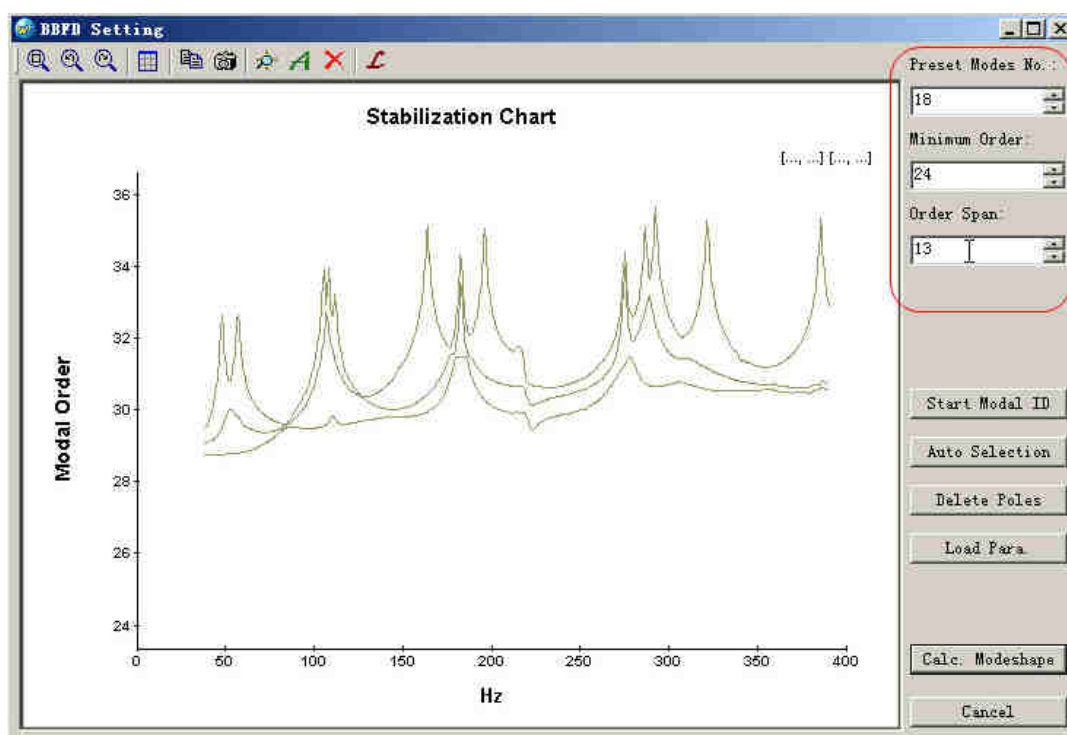

“Start Modal ID”

Press the button of “Start Modal ID” or  to obtain frequency stability diagram. This operation might take a little longer time to finish a complex structure with large number of modes and measurement coordinates. In the stability diagram, a shape symbol represents one pole. A pole in this diagram may represent a physical (i.e. structural) mode or a spurious (or noise) mode. It is normally not difficult to distinguish physical/structural mode from spurious/noise mode by the distribution of poles. Generally speaking, a physical/structural mode can be identified in each proper number of orders, while for a spurious/noise pole it usually is not the case. There are five kinds of symbols to indicate the poles:

Symbol	Description
o	The pole is not stable. (The poles obtained from the first order are always considered as unstable.)
f	The frequency of the pole does not change within the tolerance of 1%.
v	The frequency of the pole does not change within the tolerance of 1%, and the pole vector does not change within the tolerance of 10%.
d	The frequency of the pole does not change within the tolerance of 1%, and the damping of the pole does not change within the tolerance of 10%.
s	Both frequency, damping and vector are stable within the tolerances: the frequency of the pole does not change within the tolerance of 1%; the pole vector does not change within the tolerance of 10%; and the damping of the pole does not change within the tolerance of 10%.

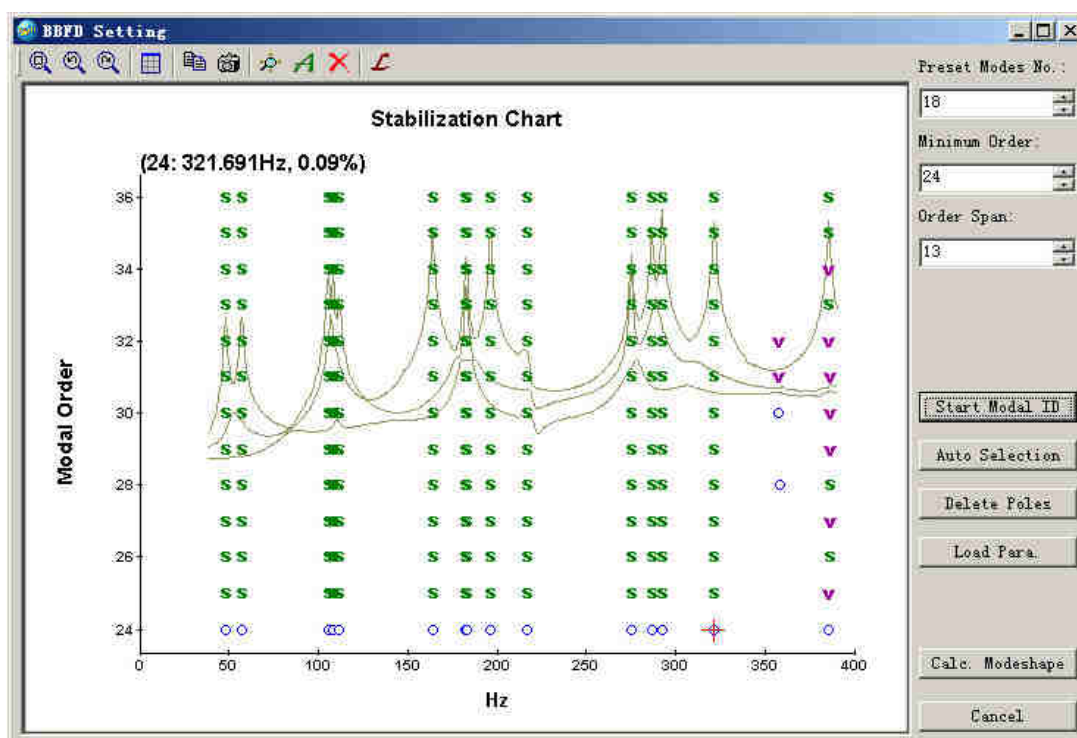

4. “Auto Selection” of structural modes

Press the button of “Auto Selection” or , the OM2 selects the physical/structural modes automatically. While move the mouse cursor on a pole, the modal frequency and damping ratio

corresponding to this pole will be shown. You can move the mouse on different poles to check the stability via small change of the modal frequency and/or damping ratio.

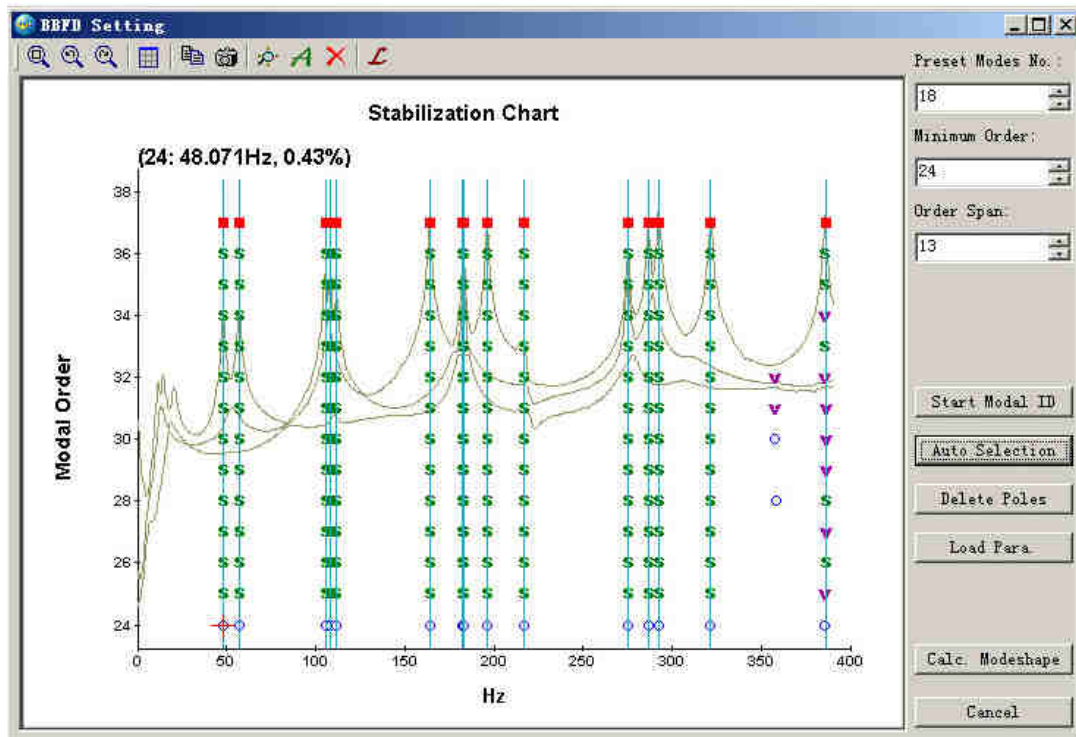

You can zoom in to check part of the stabilization diagram by click and drag a rectangle with the mouse.

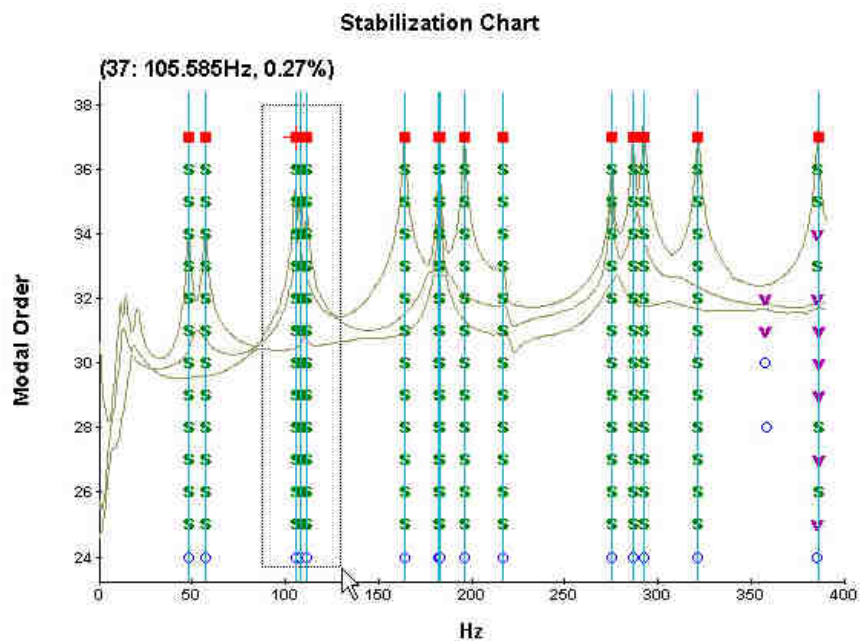

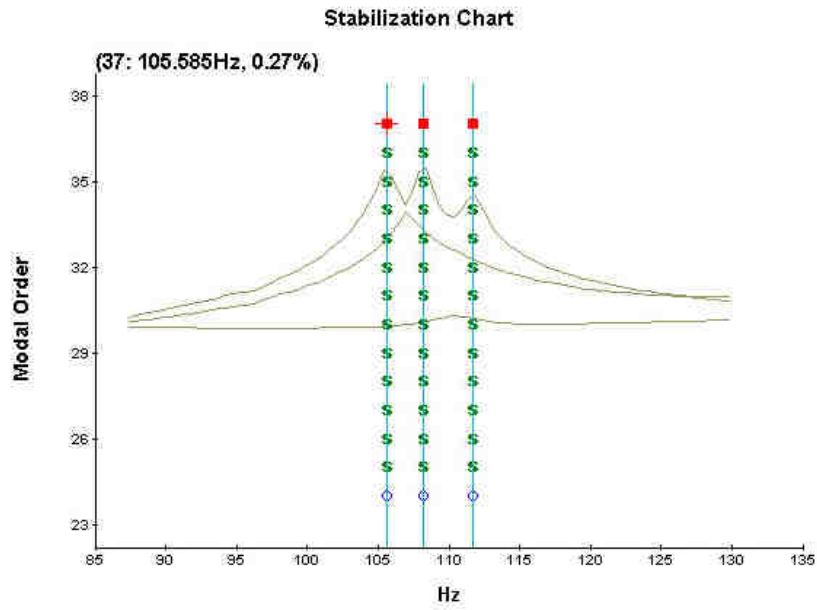

5. Manually selection of physical/structural poles

A pole can also be manually selected by clicking it or deselected it by same operation. A selected pole will be marked with a shape symbol .

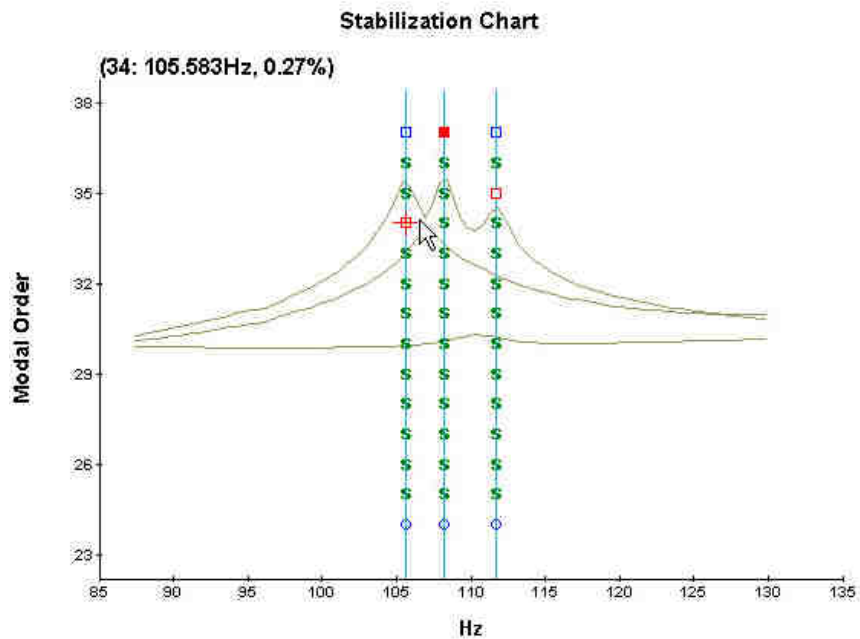

6. Mode shape calculation

Press the button of "Calc. Modeshape" to confirm the pole section and BroBand software start to estimate the mode shapes and to calculate the synthesized FRFs.

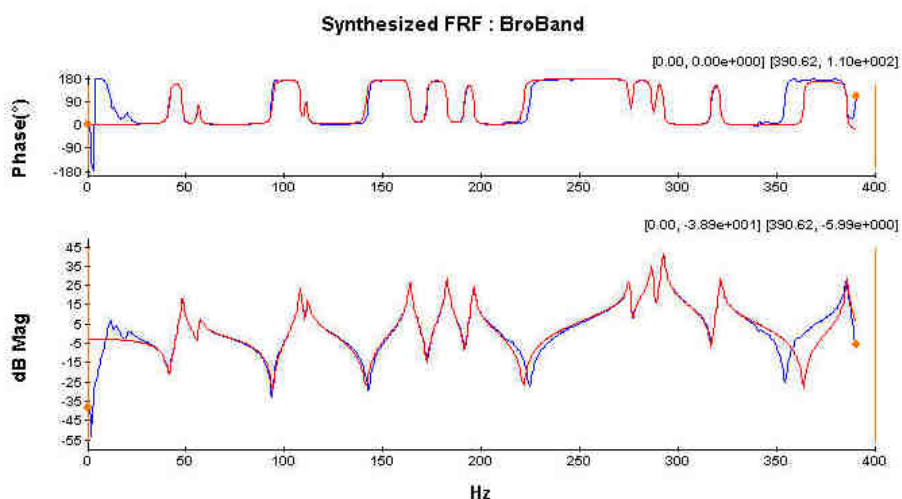

7. Inspection of identified modal parameters

Open the view of mode list. You can check the identified result here: modal frequencies, damping ratios, modal A, modal B, and mode shape animations.

No. #	Frequency (Hz)	Damping (%)	Modal A	Time	Memo
Mode 1	48.04	0.47	-2.91e+00 + 7.19e+01i	09:09:36	Likely Mode
Mode 2	58.94	0.86	4.49e-01 + 8.90e+01i	09:09:36	Likely Mode
Mode 3	105.59	0.27	-4.16e+01 + 1.44e+02i	09:09:36	Likely Mode
Mode 4	108.18	0.11	3.02e-02 + 1.64e+02i	09:09:36	Likely Mode
Mode 5	111.66	0.30	-5.56e+00 + 1.58e+02i	09:09:36	Likely Mode
Mode 6	163.92	0.14	-3.45e+00 + 1.78e+02i	09:09:36	Likely Mode
Mode 7	182.60	0.12	-2.20e-01 + 2.49e+02i	09:09:36	Likely Mode
Mode 8	182.91	0.12	-7.94e+01 + 2.71e+02i	09:09:36	Likely Mode
Mode 9	198.23	0.12	-1.03e+01 + 2.23e+02i	09:09:36	Likely Mode
Mode 10	217.07	1.13	-9.85e+02 - 4.15e+02i	09:09:36	Likely Mode
Mode 11	275.18	0.09	7.47e+00 + 3.14e+02i	09:09:36	Likely Mode
Mode 12	275.22	0.06	2.71e+01 - 3.60e+02i	09:09:36	Likely Mode
Mode 13	288.70	0.10	-3.03e+01 + 4.08e+02i	09:09:36	Likely Mode
Mode 14	292.58	0.07	-2.47e+01 + 3.89e+02i	09:09:36	Likely Mode
Mode 15	321.69	0.09	-3.08e+01 + 6.00e+02i	09:09:36	Likely Mode
Mode 16	385.97	0.02	-7.86e+01 + 2.86e+02i	09:09:36	Likely Mode







8. Continue modal identification in another frequency band

If more than one frequency band is selected, returning to the MIF plot window, and repeat the above operations. The result obtained from previous modal identification can also be loaded by pressing the button of "Load Para."

ON THE TOOLBAR OF "BBFD SETTING" DIAGRAM



	Display the full band of current curve
	Back to previous display range
	Go to next display range

	Show or hide the graph grid
	Copy contents in current main window to the clipboard
	Save current snapshot to BMP or JPG
	Start modal identification to gain poles
	Select the structural poles automatically
	Delete all the selected poles
	Load the parameters (poles, selected poles, frequency band) of previous modal identification

MODAL VALIDATION, MAC & COMAC

Modal Assurance Criterion (MAC) values can be used to compare two arbitrary complex vectors. The MAC value between two vectors who have linear relationship is near to one. The MAC value between two linearly independent vectors will be near zero. MAC calculation has two applications in the modal analysis.

First, it can be used to compare two mode shapes obtained from two different modal parameter estimation processes on the same test data. Two similar mode shapes have a high MAC value, and two same mode shapes have a MAC value of 1.



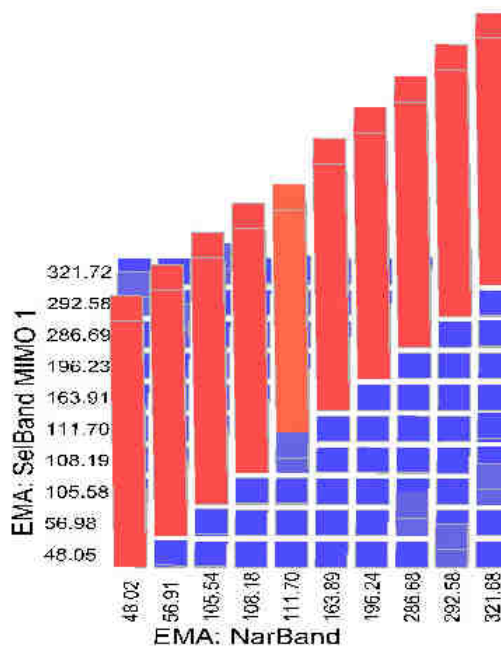

Second, it can be used to check the orthogonality of mode shapes when weighted by the mass matrix. Even when no exact mass matrix is available, the orthogonality of mode shapes is approximately satisfied. We can use it to validate the modal result.

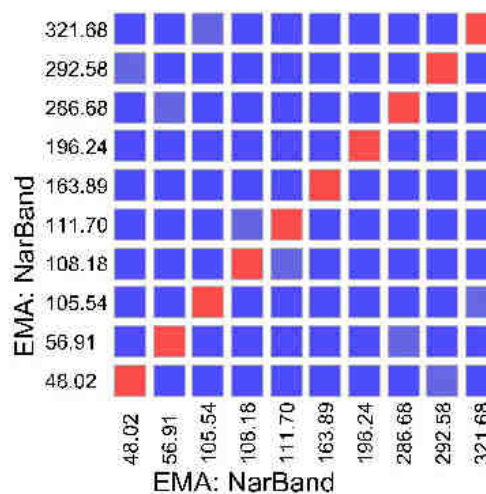

The MAC value table can also be showed by the right click popup menu.

Coordinate Modal Assurance Criterion (COMAC) is an extension of Modal Assurance Criterion (MAC). COMAC attempts to identify which measurement degrees of freedom contribute negatively to a low value of MAC. COMAC is calculated over a set of mode pairs, analytical versus analytical, experimental versus experimental or experimental versus analytical. In Modal, COMAC between modes from different identification algorithms or imported modes can be calculated.

To calculate COMAC, the first step is to set the two sets of modes you want to be compared.

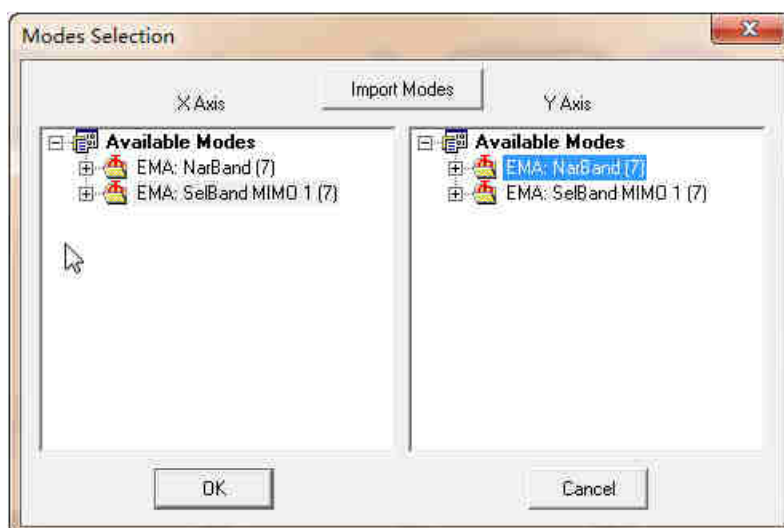

In the second step, the mode pairs should be determined. The process of modes paring will be done by Modal automatically, according to the MAC values between each modes in the two sets. You are also allowed to select part of the mode pairs.

Select	EMA: SelBand MIMO 1	Frequency	Damping Ratio	EMA: NarBand	Frequency	Damping Ratio	MAC Value
<input checked="" type="checkbox"/>	1	14.93 Hz	0.29%	1	14.92 Hz	0.30%	99.95
<input checked="" type="checkbox"/>	2	25.56 Hz	0.31%	2	25.56 Hz	0.30%	99.68
<input checked="" type="checkbox"/>	3	36.41 Hz	0.16%	3	36.41 Hz	0.15%	99.77
<input checked="" type="checkbox"/>	4	49.76 Hz	0.13%	4	49.75 Hz	0.13%	99.96
<input checked="" type="checkbox"/>	5	57.08 Hz	0.18%	5	57.08 Hz	0.17%	99.83
<input checked="" type="checkbox"/>	6	70.28 Hz	0.20%	6	70.27 Hz	0.21%	99.97
<input checked="" type="checkbox"/>	7	76.15 Hz	0.12%	7	76.16 Hz	0.14%	99.70

Then the COMAC values table will be displayed.

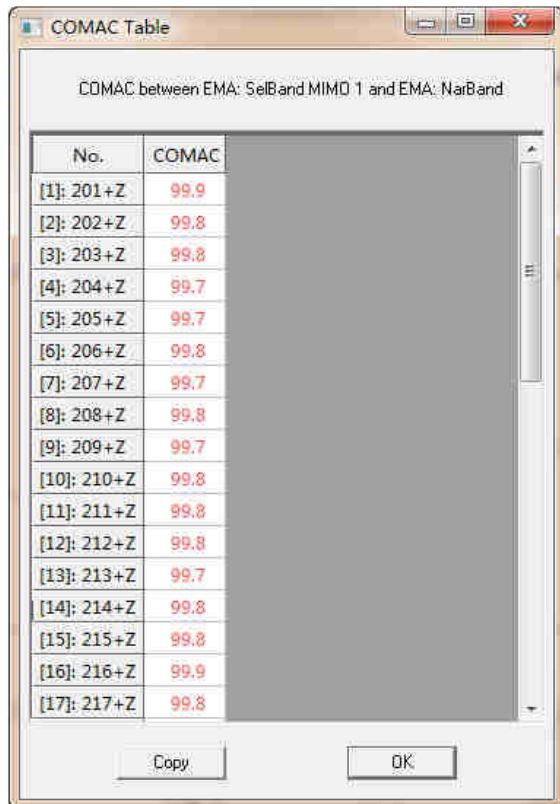

COMAC Table

COMAC between EMA: 5elBand MIMO 1 and EMA: NarBand

No.	COMAC
[1]: 201+Z	99.9
[2]: 202+Z	99.8
[3]: 203+Z	99.8
[4]: 204+Z	99.7
[5]: 205+Z	99.7
[6]: 206+Z	99.8
[7]: 207+Z	99.7
[8]: 208+Z	99.8
[9]: 209+Z	99.7
[10]: 210+Z	99.8
[11]: 211+Z	99.8
[12]: 212+Z	99.8
[13]: 213+Z	99.7
[14]: 214+Z	99.8
[15]: 215+Z	99.8
[16]: 216+Z	99.9
[17]: 217+Z	99.8

Copy OK

IMPORT / EXPORT

Data and all kinds of results can be exported or printed, which provides you great convenience to write a report or give a presentation. These functions include: Importing data, exporting data, exporting tables, export graphics, exporting animations, print preview and print.

IMPORT

GEOMETRY

You can import geometry information from UFF 15/82/2412 files and IGES files

DATA FILES

UFF

You can import measurement data in frequency domain (including Frequency Response Functions and Coherence Functions) or time domain (time histories) from the UFF 58/58b files.

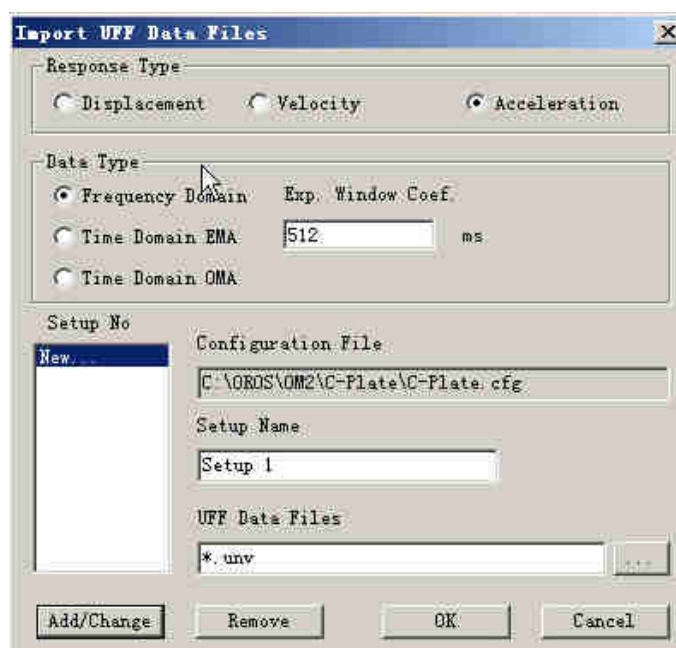

1. Response Type

The type of response to be imported. Generally we use accelerometers, so we specify the type as "Acceleration" here.

2. Data Type

The type of data to be imported. There are three types here: 1) frequency response functions (and coherence functions) for EMA analysis, 2) time histories for EMA analysis, and 3) time histories for OMA analysis.

If FRFs which have been applied with exponential windows are to be imported, you need fill the content of "Exp. Window Coef." to modify the increasing damping caused by the exponential window.

If time histories are to be imported, you need specify the marker to distinguish excitation signal from response signal. Here you have two options: reference DOF (REFDOF) or the unit of Y Axis. When the marker is REFDOF, the measurement information of excitation signal should be defined in the field the reference node and direction. While the marker is the unit of Y Axis, software take the signal block with the unit you specified as excitation signal.

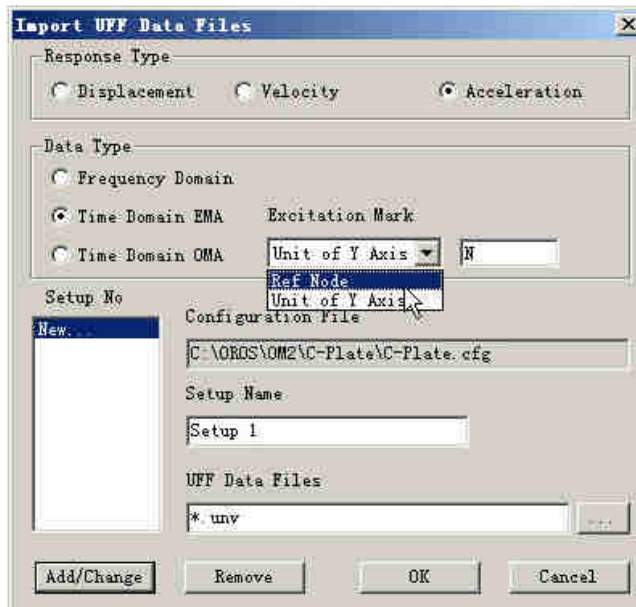

3. Setup Name and UFF Data Files

Then you can specify or modify the "Setup Name" and "UFF data files" for each setup. The wildcards ('*' or '?') is allowed to refer to multiple UFF files. If many files are included, you are recommended to use wildcards manually. The common definition of wildcards is employed: "*" to represent any multiple characters, and '?' to represent a single character. For example, the "*.unv" represents all the files whose extension names are "unv" in the same directory of this configuration file.

Note (very important): if you want to import time domain UFF data files for EMA, you'd better use the wildcard. You must put the measurement data of one test (for example, in the IMRT, one test means the measurement of one point) into one UFF file. If you have 20 nodes to measure in an IMRT, then you should have 20 UFF files, such as node01.uff, node02.uff, ... node20.uff. Here you can use "node*.uff" to import all the 20 files.

4. Buttons

Press the "Add/Change" button to confirm this operation, then these data files information will be stored for the specified setup. For an EMA test, you are only allowed to have one setup, no matter whether it is time domain or frequency domain. For an OMA test, you are allowed to add more setups.

Press the "OK" button to write these information to the current configuration file, and the new configuration file will be automatically reloaded to import the data specified.

The following interface will appear after the importing:

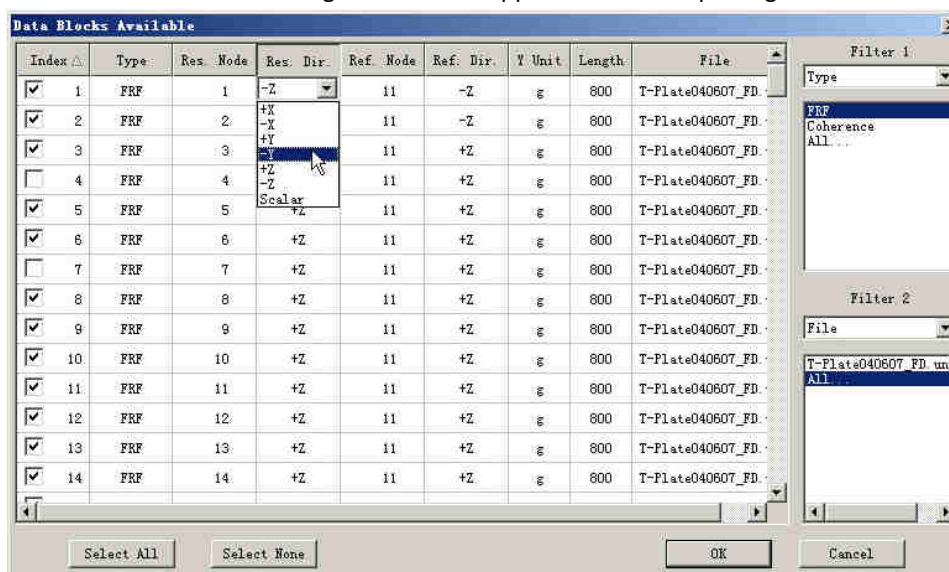

You can check or change the information of imported data here, such as the response nodes and directions. You can also unselect the data you don't like. Click the header of each column, the current list will be sorted. In the right of this dialog, two filters are set for convenience.

OROS FORMAT

You can import measurement data in frequency domain ("*.res", including Frequency Response Functions and Coherence Functions) or time domain ("*.oxf" or "*.oxl", time histories) from the OROS format data files.

The interface for importing OROS format data files is very similar with the one for importing UFF data.

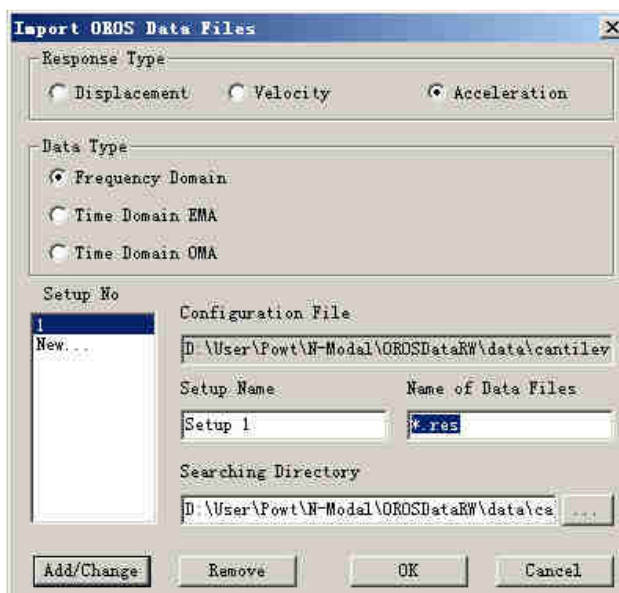

To import the FRFs and COHs from the OROS ".res" files, you don't need to specify the the "Exp. Window Coef.". Because this information is included in the ".res" file, and will be read by OM2 automatically.

The data files of one modal test may be stored in many different directories, so in this interface you should specify the "Searching Directory", but not the name of files. OM2 will search data files in the specified directory and all its subdirectories.

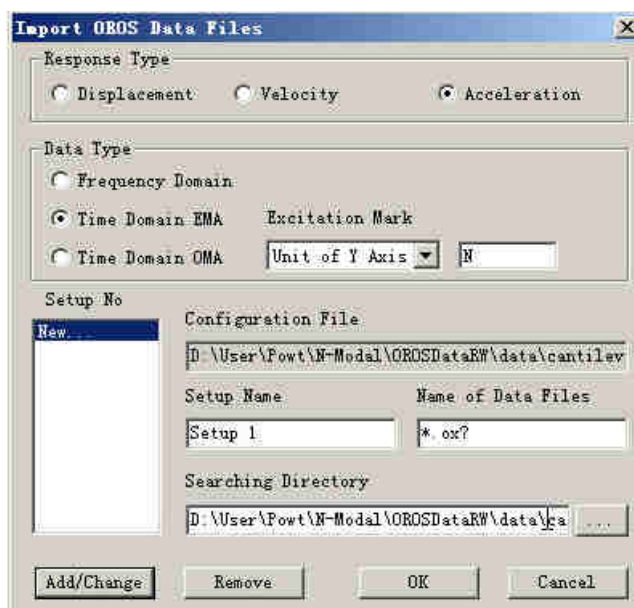

The same interface which allows you to check and change the information of imported data will appear after the configuration file is reloaded.

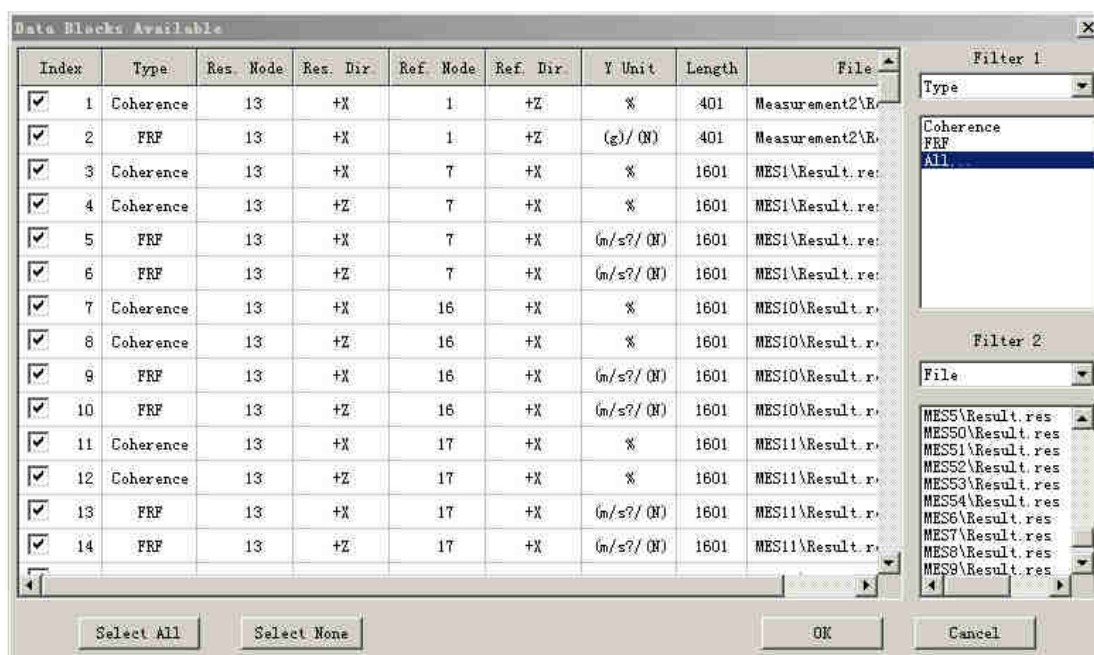

EQUATIONS

You can import the constrain equations from a ASCII format configuration file. The imported equations will be appended to the current equations list in the project. Please note that the sequence of equations is very important, which might lead to different animation effect.

MODES

You can import identified modes (including frequencies, damps, mode shapes, modal A and modal B) from UFF 55 files. An item called "Imported" will appear in the branch of "Data\Setup?\Mode" in the "Data" page of "Workspace" Panel.

EXPORT

Data and all kinds of results can be exported or printed, which provides you great convenience to write a report or give a presentation.

DATA

You can export the modes by corresponding toolbar of the mode list view  or the right click menu.



All the mode can be exported to a UFF 55 file (".unv") or ASCII file (".asc").

Data such as input signals, output signal, frequency response functions, power spectrums, and coherences can be exported to UFF files or ASCII files in the "Data" tab page of Workspace shortcut panel.

All the data in the data table view can be exported to an ASCII file.

TABLE

The identified mode list can be export to Microsoft WORD as an table by the following steps:

1. Copy the Mode List to Clipboard

'Copy' button  in the standard toolbar or 'Copy All' item in the right click menu of the mode list view can be used to copy all the modes to system's clipboard. If only part of the modes are needed, please select the items you wanted by 'Shift' or 'Ctrl' keys (just like the operations in the Windows' Explorer), then click on the 'Copy' item in the right click menu.

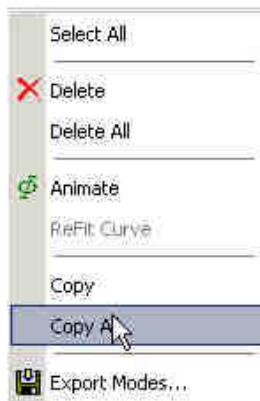



2. Paste to WORD and Create the Table

Run WORD and create a new document, and paste the contents in the clipboard into it. Select the pasted lines, and use the Insert Table Command, the a new table containing the modes are created. To prettify this table, you can adjust it furthermore.

If you want to use these tables in Microsoft PowerPoint, you can create the table in WORD first, and then copy it to the PowerPoint.

GRAPHICS

Everything in the main window, including the 2D curves, 3D graphics, data tables and so on, can be captured and saved as BMP or JPG graphic files by the 'Save Snapshot' button  in the standard toolbar.

You can also copy a snap into Windows' clipboard by the 'Copy' button  in the standard toolbar, and then paste it to the document.



ANIMATIONS

The animations of mode shapes or ODS in Modal can be saved as AVI media files according to the following steps:

- Make sure that the mode shape or ODS wanted is shown in activated.
- Press the "Record" button  in the "3D Display" shortcut panel (or using the right click menu), and enter the wanted file name. The default name can be changed from the dialog of "Set Properties...".
- Saving progress will be displayed in the status bar. You can play this AVI file with some media player, or insert it to the WORD/PowerPoint documents.
- The AVI file is encoded with the CODEC you set in the dialog of "Set Properties...". Some CODECs might fail to work correctly. If this happens, please select another one in the dialog of "Set Properties...".

- Different CODEC leads to different play quality and different file size, you can select the best after trying all.

PRINT

Everything displayed in the main window, including the 2D curves, 3D graphics, configuration information, data tables and so on, can be previewed by  button or printed by  button in the standard toolbar. Of course, you can realize these operations by menu too.

SHORTCUTS OPERATION

Many shortcuts are provided to help you operate Modal more conveniently. Your efficiency can be greatly improved by these shortcut operations employing the mouse and keyboard.

SHORTCUT OPERATIONS IN THE EXPLORER

Double click on a '.cfg' file	Run Modal, and open this configuration file
--------------------------------------	--

Double click on a '.wsp' file	Run Modal, and load this workspace file
--------------------------------------	---

Drag a '.cfg' file to the software's mainframe	Open this configuration file
---	------------------------------

Drag a '.wsp' file to the software's mainframe	Load this workspace file
---	--------------------------

SHORTCUT OPERATIONS IN THE GENERAL INTERFACE

Ctrl+N	Create a new configuration file
---------------	--

Ctrl+O	Open a configuration file
---------------	---------------------------

Ctrl+P	Print contents in the current window
---------------	--------------------------------------

Ctrl+C	Copy contents in the current window to the clipboard
---------------	--

Ctrl+V	Insert clipboard contents
---------------	---------------------------

Ctrl+Z	Undo the last action
---------------	----------------------

Ctrl+Y	Redo the previous undone action
---------------	---------------------------------

Ctrl+D	Locate to the setup list box in the standard toolbar, and switch between each setup
---------------	---

F1	Show the online help manual
-----------	-----------------------------

F5	Reload the current configuration file
-----------	---------------------------------------

F12	Begin a new session of OROModal2
------------	----------------------------------

Double click on a window tab	Close the relevant window
-------------------------------------	---------------------------

Middle click on a window tab	Close the relevant window
-------------------------------------	---------------------------

SHORTCUT OPERATIONS IN THE 2D CURVE WINDOW

Double click	Select the band between current cursors
Enter	Select the band between current cursors
Middle click	Delete the latest selected band
Backspace or Delete	Delete the latest selected band
Double middle click	Delete all the selected bands
Esc	Delete all the selected bands
Tab	Find the limits between current cursors
←	Move the two cursors to the left simultaneously
→	Move the two cursors to the right simultaneously
↑	Move the two cursors outwards simultaneously
↓	Move the two cursors inwards simultaneously
Page Up	Increase the cursors' moving step
Page Down	Decrease the cursors' moving step
Home or End	Make the two cursors return to default positions
F2 + Mouse moving	Move the two cursors with the mouse simultaneously
F3 + Mouse click	Zoom in the range between the two cursors
F4 + Mouse click	Display the full band of current curve

SHORTCUT OPERATIONS IN THE 3D GRAPHICS WINDOW

Ctrl+M	Locate to the mode list box in the toolbar, and switch between each mode
Click and moving	Rotate the model
F2 + mouse moving	Translate the model or selected 3D objects
F3 + mouse moving up or down	Zoom in or out the model or selected 3D objects

F4 + mouse moving	Rotate the model or selected 3D objects
Mouse wheel scroll	Zoom in or out the model or selected 3D objects
Delete	Delete selected items (nodes, lines, polygons, 3D objects)
←	Translate to the left
→	Translate to the right
↑	Translate to the top
↓	Translate to the bottom

SHORTCUT OPERATIONS IN THE DIALOG OF 'SHOWED SERIES'

Double click on the 'Available No.'	Add the selected items to 'Selected No.'
Double click on the 'Selected No.'	Delete the selected items from 'Selected No.'
Right click anywhere	Delete all the items in 'Selected No.'
Middle click anywhere	Delete all the items in 'Selected No.'

Advanced Swept Sine

TABLE OF CONTENTS:

ADVANCED SWEEP SINE INSTALLATION GUIDE	96
First checking.....	98
Recommended PC configuration:	98
OROS and Microsoft software required for operating Advanced Swept Sine:.....	98
Equipment required for the installation:.....	98
Operating Systems compatible with Advanced Swept Sine	98
Presentation of OR3X Hardware	98
Installation	99
Installation of the NVGate [®] software	99
Installation of the Advanced Swept Sine Solution	99
Troubleshooting	103
ADVANCED SWEEP SINE USER'S MANUAL.....	104
Introduction	105
Advanced Swept Sine Basics.....	106
General processing Description	106
Splitting measurement into spans.....	106
Measurement technique and accuracy.....	106
Boosted measurement mode	107
General smoothness	107
General level control	107
Multi excitations.....	108
Advanced Swept Sine implementation	109
Measurement block diagram	109
Basic measurement timing.....	110
Starting Advanced Swept Sine.....	111
Menus options.....	112
File menu.....	112
Open	112
New.....	112
Save/Save As.....	112
Exit	112
Results menu.....	112
Transfer function	113
Coherence.....	116
Measurement reference level	116
Measurement response level	117
Edit menu	117
Edit Settings.....	117
Edit Input	117

Editing and saving settings	118
General settings	118
Span settings	120
NVGate settings.....	124
Saving settings.....	126
Measurement storage.....	127
Saving results in NVGate	127
Log file description	127
Measurement examples	128
Modal measurement.....	128
Acoustic measurement	131
Specifications.....	136

ADVANCED SWEPT SINE INSTALLATION GUIDE

Thank you for purchasing the Advanced Swept Sine Software.

The **OROS ADVANCED SWEPT SINE SOLUTION** is a dedicated tool for your Advanced Swept Sine measurements. It is specifically designed to allow accurate and efficient tests. Based on the main international standards, it allows a flexible setup and a guided measurement procedure.

The Advanced Swept Sine Solution is meant to work in combination with its associated Analyzer software **NVGATE**[®]. In this way, the full power of the **NVGATE**[®] platform and associated multi-channel **INSTRUMENT HARDWARE** is made fully available for your objective: Transfer Function measurement.

This "**INSTALLATION GUIDE**" will guide you through the installation of the Advanced Swept Sine software and help you run it for the first time. It will explain in particular the way the installation should be done in parallel to **NVGATE**[®] and to the Instrument Hardware.

Now, let's get started with your **ADVANCED SWEPT SINE SOLUTION!**

FIRST CHECKING

RECOMMENDED PC CONFIGURATION:

Minimum	Pentium 4/ 2 GHz / 256 ¹ MB RAM with Windows XP or 512 ¹ MB with Windows Vista/ Graphics video adapter with at least 32 MB memory / 150 MB free on HD + storage for measurements and signals, 1024 x 768 display (XGA), DirectX 8.0
Recommended (for laptop)	Dual/quad core processor (ex: Intel Core i5) / > 2.5 GHz / 4 GB of RAM / Graphics video memory 1 GB / 1 GB free on HD + storage for signals / CD or DVD ROM drive / 1440 x 900 display / Windows 7 pro
Recommended (for desktop)	Quad core processor (ex: Intel Core i7) / 6 GB of RAM / Graphics video memory 1 GB / 1 GB free on HD + storage for signals / CD or DVD ROM drive / 1920 x 1080 display / Windows 7 pro
Connection	Type: Ethernet 100base TX , 100 Mbit/s - Connector: RJ45 For removable disk: USB 2.0 - At least one USB port for dongle key.
Operating systems	Windows XP Pro Service Pack 3, Windows Vista Business Service Pack 2, Windows 7 (recommended)

OROS AND MICROSOFT SOFTWARE REQUIRED FOR OPERATING ADVANCED SWEPT SINE:

NVGate[®] must have been installed before installing Advanced Swept Sine.

NVGate[®] version 4.10 or higher is required for operating Advanced Swept Sine.

Warning: Advanced Swept Sine version 2.3 is not compatible with NVGate[®] version 6.00.

EQUIPMENT REQUIRED FOR THE INSTALLATION:

Software CD containing Advanced Swept Sine and the Online Help.

OPERATING SYSTEMS COMPATIBLE WITH ADVANCED SWEPT SINE

Microsoft Excel[®] and Word[®] 2000 or higher are required for operating NVGate[®]
Windows 2000 Service pack 4, Windows XP Professional Service pack 2, and Adobe Acrobat Reader 6.0 and higher (for the documentation).

PRESENTATION OF OR3X HARDWARE

For the presentation of 3-Series Hardware, please refer to the NVGate User's manual.

INSTALLATION

INSTALLATION OF THE NVGATE® SOFTWARE

NVGate® version 4.10 or higher must be installed on the PC before starting the installation of Advanced Swept Sine.

To install NVGate®, please refer to the NVGate User's manual

Before starting the installation of Advanced Swept Sine, make sure that NVGate is properly installed.

If not, please refer to the Troubleshooting section of the NVGate User's manual.

INSTALLATION OF THE ADVANCED SWEPT SINE SOLUTION

Ensure NVGate® is installed and running on the PC before starting the installation of Advanced Swept Sine.

The procedure of installation of Advanced Swept Sine is the same for Windows 98SE, 2000 and XP.

For information, the following screenshots have been realized under Windows XP.

Insert the CD in the appropriate drive and wait for the Autorun program (or run the "setup.exe" program from the CD)

Wait until the following window is displayed:

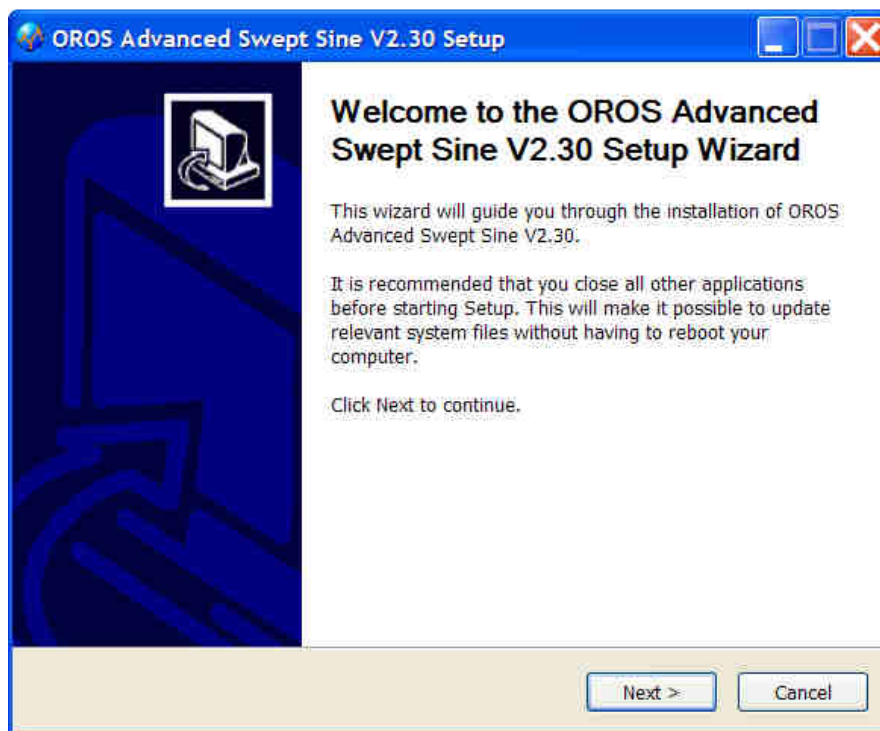

Click on "Next >".

The following window is displayed:

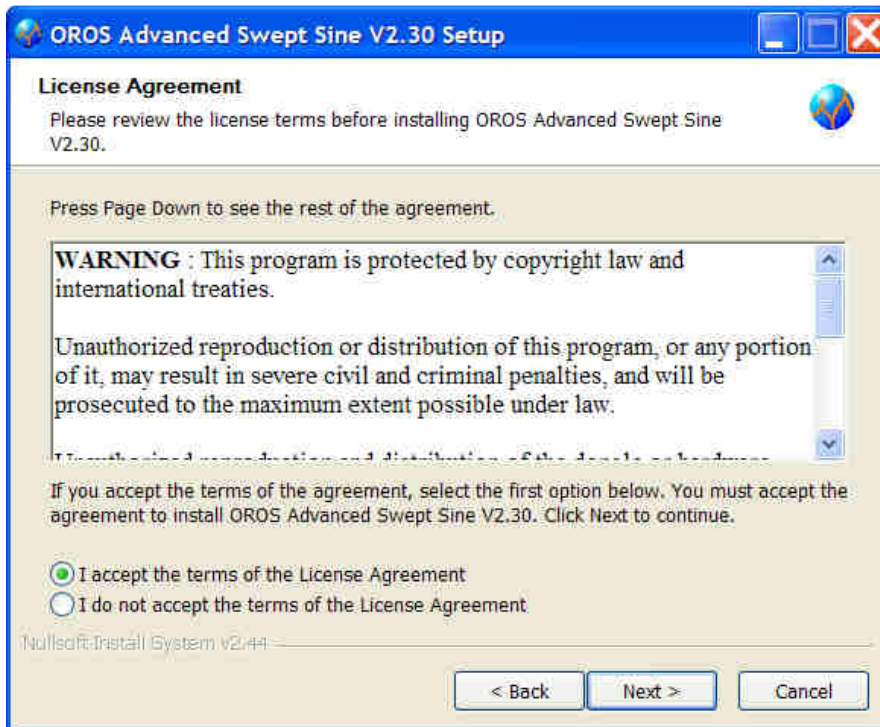

Read the terms of the license agreement and select "I accept the terms in the license agreement" if you agree.

Click on "Next >".

The following window is displayed:

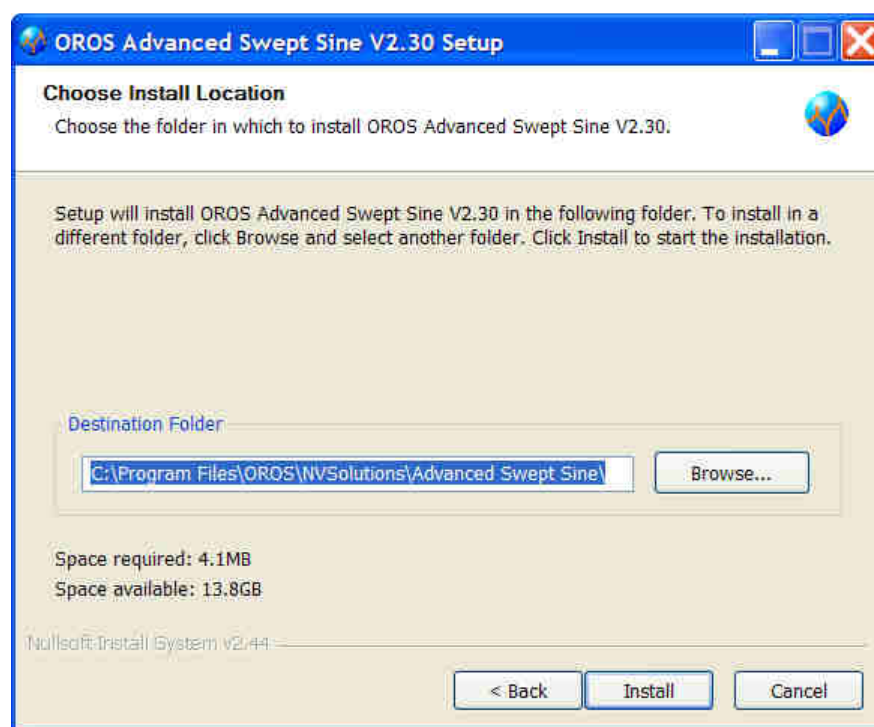

Select the location of the "Advanced Swept Sine" folder. By default, OROS Sound Power is installed in: C:\Program Files\OROS\SweptSine.

Installing Advanced Swept Sine in the NVGate[®] directory (as it is by default) enables links between the Sound Power Online Help and the NVGate[®] Online Help.

Click on "Install" to begin the installation.

Wait until the following window is displayed:

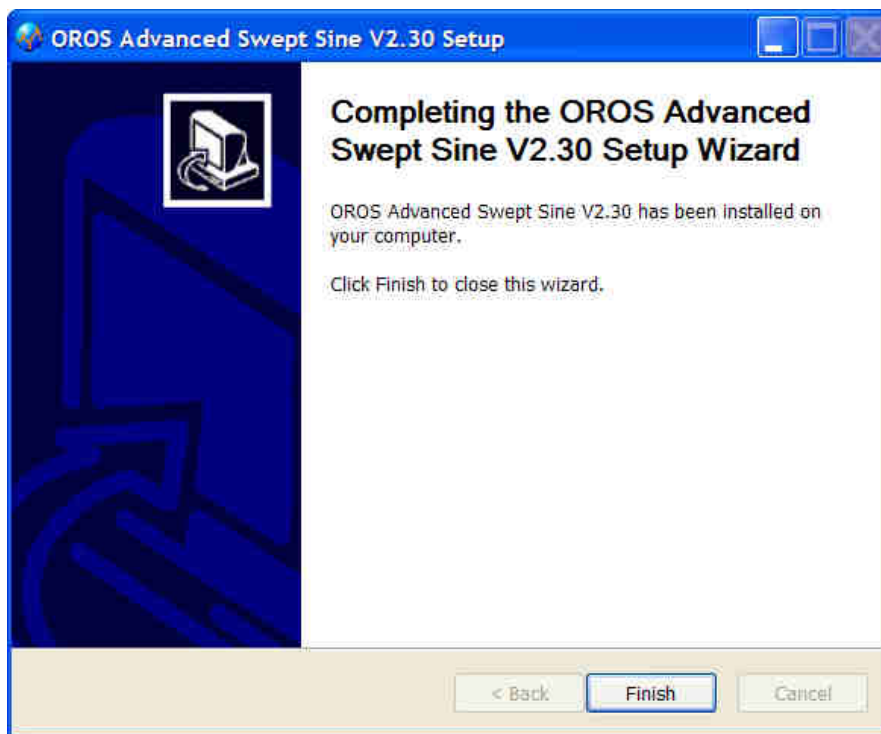

Click on "Finish".

The following window is displayed:

Advanced Swept Sine is now installed!

At this stage:

Plug the **Hardware** to use Advanced Swept Sine in the **Connected Mode**.

And then, run "Advanced Swept Sine".

The following window is displayed:



TROUBLESHOOTING

Advanced Swept Sine may not start.

In this case, one of the following error messages is returned:

« Connection to NVGate has failed ! »

If NVGate location is = Local:

Check that NVGate is running. If not, escape from Advanced Swept Sine and run it again

Check that NVGate can start on its side

If NVGate location is = Remote:

Check that NVGate is running on the remote PC

« You don't have the permission to use OROS Advanced Swept Sine ! »

Ensure that you are using a dongle configured for Advanced Swept Sine

Contact your OROS Agent

ADVANCED SWEPT SINE USER'S MANUAL

INTRODUCTION

Traditionally transfer function of a system is measured using FFT based measurement with broadband excitation (as random noise or multi-sine). With only one average all frequency points of transfer function can be measured. Some limitations appear as:

- Transfer function frequency resolution is limited to FFT resolution,
- Excitation power is broadband and at each frequency line signal noise ratio can be poor with low coherence,
- No control of saturation and level on response,
- Ratio between lower and upper frequency is limited by number of FFT lines.

Swept sine technique (also called Servo Analysis, Network Analysis, or Swept Sine) automatically sweeps a sine wave over the frequency range of interest and measures the response frequency point by frequency point. Using a pure sine excitation optimizes measurement at each frequency step:

- Preventing overload,
- Measurement at any frequency
- High frequency ratio, combined with high frequency resolution,
- Fine control of level,
- Measurement time optimized with frequency,
- Excitation level depending of frequency,
- No error between frequency lines due to non-linearity.

So using pure sine excitation, large frequency spans are possible with linear or logarithmic progression. Advanced Swept Sine automatically takes care of settings as FFT frequency range, number of FFT lines, average size...

ADVANCED SWEPT SINE BASICS

GENERAL PROCESSING DESCRIPTION

In Advanced Swept Sine, for each frequency point of transfer function:

- First, sine generator sweeps smoothly to target frequency.
- Then Advanced Swept Sine waits for a user-defined fixed or frequency dependant delay in order to guarantee stabilization of system under measurement.
- And finally using selected lines from an averaged cross-FFT measurement; transfer function for this frequency point is computed and saved. FFT average time can be either fixed or frequency dependant.

Optionally Advanced Swept Sine can adjust and limit generator output level in order to get either predefined or limited level at input and output of system under measurement. Level can be frequency dependent, for example to adjust displacement on a shaker at each frequency.

SPLITTING MEASUREMENT INTO SPANS

A complete measurement frequency range can be broken into up to 8 separate frequency spans; this multi-span capability is useful, for example, to define different frequency step sizes on the whole frequency range or to adjust excitation level on different frequency ranges.

A measurement can be processed with frequency increase or decrease and possibility to skip any span.

MEASUREMENT TECHNIQUE AND ACCURACY

Swept sine technique has been introduced in 80's based on time domain for processing and time domain integration of signals, but this technique is sensitive to harmonics. Some other systems are based on a tracking filter, but with a lack of bandwidth control on large frequency spans.

OROS Advanced Swept Sine is based on FFT processing with careful designed algorithms. This FFT processing provides no sensitivity to harmonics and provides adaptive bandwidth measurement with frequency.

FFT frequency range is automatically adjusted during the measurement in order to get optimum resolution and averaging time. Averaging time can be set as a number of periods of excitation signal, so more time can be spent at low frequencies and less time at high frequencies.

In the worst case, maximum error on transfer function, due to OROS measurement technique, is lower than 0.012 dB on magnitude response and 0.02° on phase response at any measurement frequency. This is a repeatability error to add to OROS 3-Series analyzer precision (typical 0.05 dB and 0.05° see product specification).

Measurement frequency can be set between 0.01 Hz and 40 kHz. Absolute frequency resolution of generator is better than 0.00002 Hz.

BOOSTED MEASUREMENT MODE

BOOSTED mode lowers measurement time while preserving resolution. In many cases it is desirable to sweep over a large frequency range while detecting narrow features in the transfer function, with the consequence of a large number of frequency points and then a long measurement time.

The optional BOOSTED mode provides faster overall measurement by skipping measurement of successive frequency points with no significant frequency response changes. This boosted swept sine mode includes simultaneous monitoring of both amplitude and phase variations in order to be efficient with complex transfer function including many resonances and anti-resonances.

GENERAL SMOOTHNESS

Advanced Swept Sine uses as generator the "Advanced sine output signal" available in NVGATE. This guarantees smooth transitions during frequency and amplitude changes.

During sweep to next frequency point, the instantaneous frequency changes at a user defined rate with no brutal phase, frequency variations. This method gives a better output signal smoothness than, for example, frequency change at signal zero crossing.

Amplitude variation is also controlled in the same way with user-defined duration for amplitude change.

Relative precision of generator frequency is better than 10^{-5} that means very closed frequency points can be processed with accuracy by Advanced Swept Sine.

GENERAL LEVEL CONTROL

For each frequency measurement the user defines a target level that can be frequency fixed or dependent. This target level can be used in 3 ways:

- As a generator output level,
- As a target level at system input under measurement (useful with actuator),
- Or as a target level at system output.

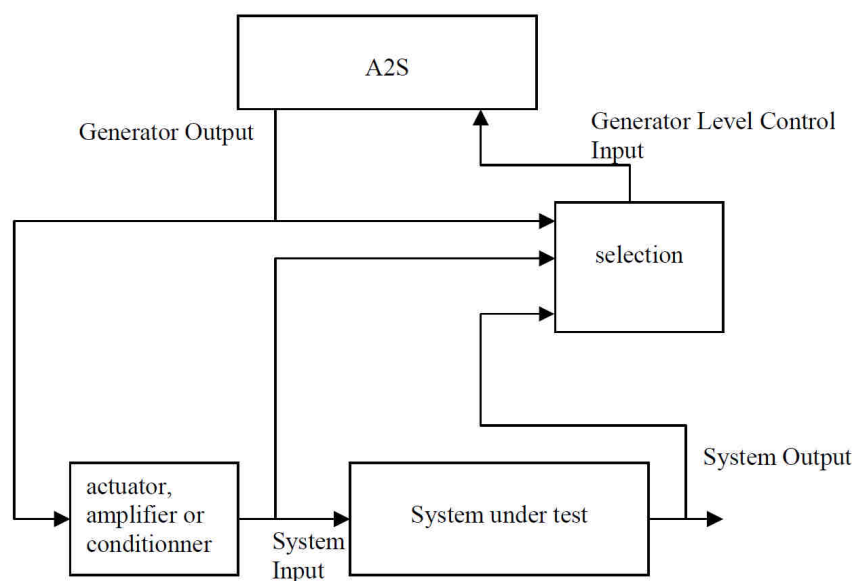

In the last two ways, for each frequency point Advanced Swept Sine automatically adjusts generator output in order to get target value with a user-defined tolerance. It stops adjustment after the user-defined maximum number of tries.

The Advanced Swept Sine also includes user defined signal level limitations at system input or output. If measured value is greater than defined limit Advanced Swept Sine automatically lowers target level value and retries frequency point measurement.

Level adjustment function associated with signal limiting function can help measurement, reducing input level at a resonance (or pole) to avoid non-linearity, or increasing level where there is anti-resonance (or zero) to get better measurement.

MULTI EXCITATIONS

For measurement on complex mechanical systems that need multi excitation with different amplitude or phase, the multi generator outputs of OROS 3-Series can be used.

ADVANCED SWEPT SINE IMPLEMENTATION

The Advanced Swept Sine analyzer is a separate application controlling OROS 3-Series NVGATE software through standard NVDRIVE, the programming interface to NVGate.

MEASUREMENT BLOCK DIAGRAM

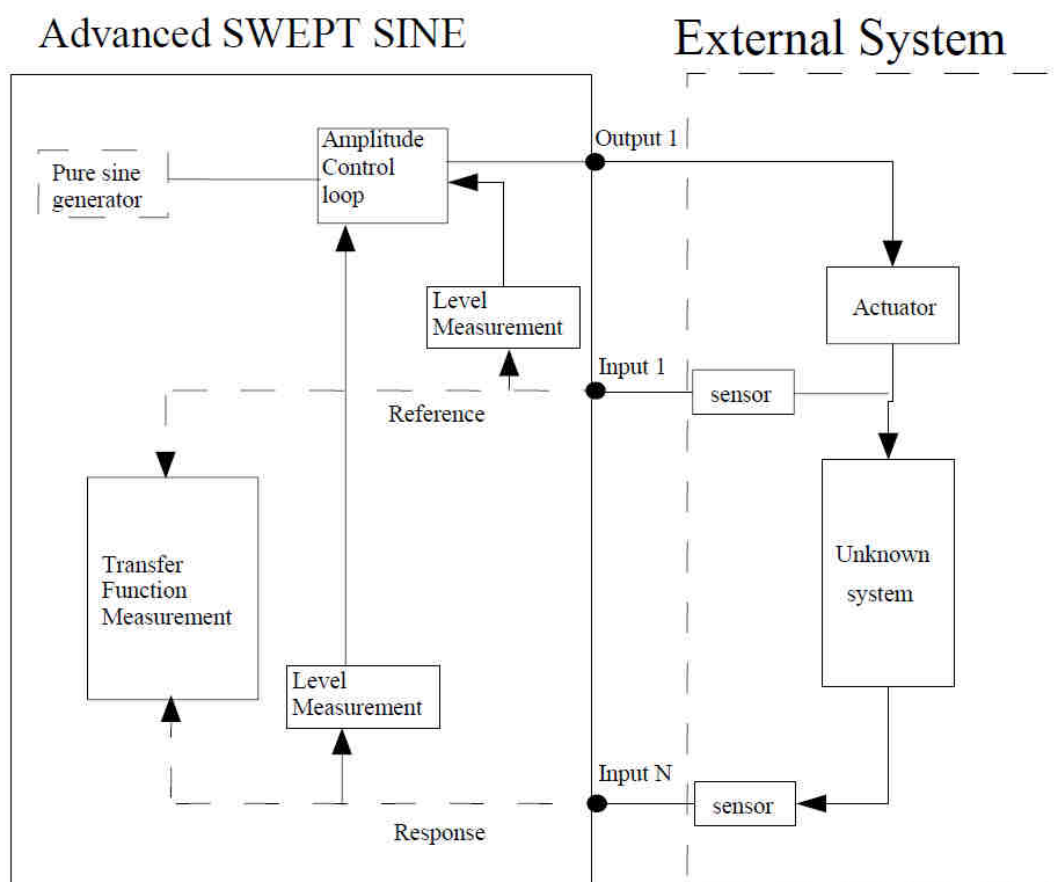

On OROS 3-Series, output channel 1 is used for excitation, input channel 1 for input of system under measurement and is called excitation measurement and the user-selected input channel for corresponding output called response measurement. A selection of the number of response inputs is also available (see below).

OROS 3-Series advanced pure sine generator delivers excitation signal with smoothed amplitude and frequency variations. On excitation and response channels level measurement is obtained from FFT spectrum. These levels are used by amplitude control loop, which takes into account target level and user defined limitations.

Transfer function measurement at each frequency point is obtained from corresponding lines of FFT spectrum and cross spectrum measured by OROS 3-Series, average time being adjusted for each

frequency point. When necessary the swept sine controller switches FFT frequency ranges in order to get optimum time measurement and bandwidth measurement.

Final transfer function is computed step by step by swept sine control and displayed, saved or exported through NVGATE. During processing all relevant information including rejected measurements (for example during target level adjustment) are stored in a text log file for optional processing and full trace analysis.

An example could be done with multi-span

BASIC MEASUREMENT TIMING

For each basic measurement step we have the following timing:

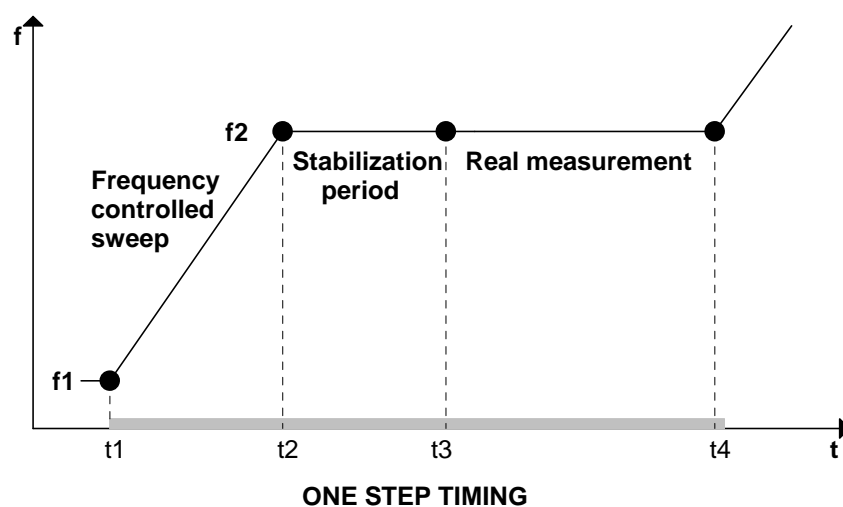

- The generator frequency (and/or the amplitude) sweeps to the new value
- The analyzer waits for the system under measurement to stabilize. This delay is specified as a minimum time and/or a minimum number of sine periods. This delay can also be set down to zero.
- The analyzer does real measurement using averaging. The average time is specified as a minimum time (greater than 30 ms) and/or a minimum number of sine periods (greater than 10).

STARTING ADVANCED SWEPT SINE

Warning: before starting Advanced Swept Sine, NVGate must be running.



Run: button for starting a measurement.

Pause/continue: button for manual pause measurement.

Stop: button for manual stop measurement.

Span: progress bar which indicates on which span is the current measurement.

Try: this shows the current try number for frequency point.

Progress: this bar is the evolution of the current measurement for the entire range frequency.

MENUS OPTIONS

FILE MENU

OPEN

Open an Advanced Swept Sine project previously saved (.sws), this will load the settings of this project.

NEW

Open a new project with a default configuration.

SAVE/SAVE AS

Using this menu to save settings of your current Advanced Swept Sine measurement and your project.

Note that to save results you may use the NVGate 'save results'.

Note: When the settings are saved in a file "file_name.sws", if the current project in NVGate is the default project the project would be automatically renamed as "SWS_file_name".

EXIT

Close the Advanced Swept Sine solutions

RESULTS MENU

Note: in all kind of graphs displayed, if one span is in mode 'log' then X-axis is displayed in log.

Select the results you want to display in the following window:

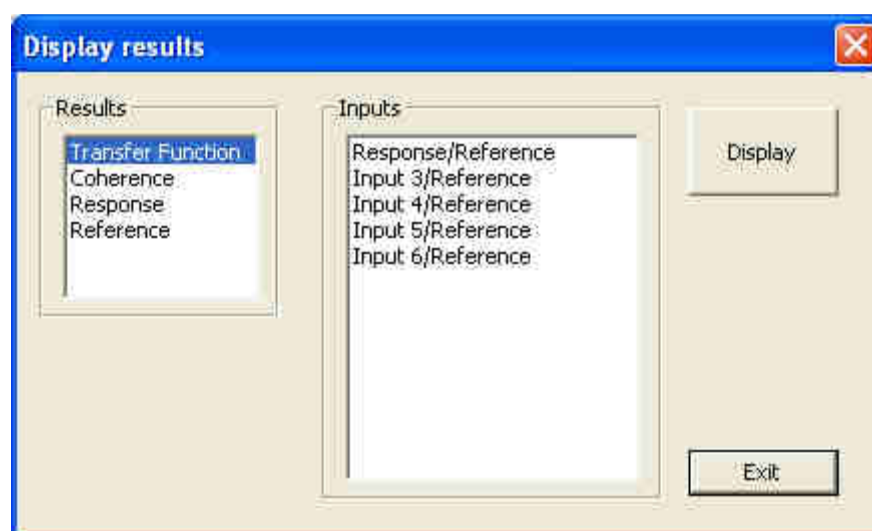

Results from the same group will be displayed in the same window.

Following graphs are just examples of the different graphs the user can display.

TRANSFER FUNCTION

The transfer function could be displayed as following:

➤ Magnitude/Phase

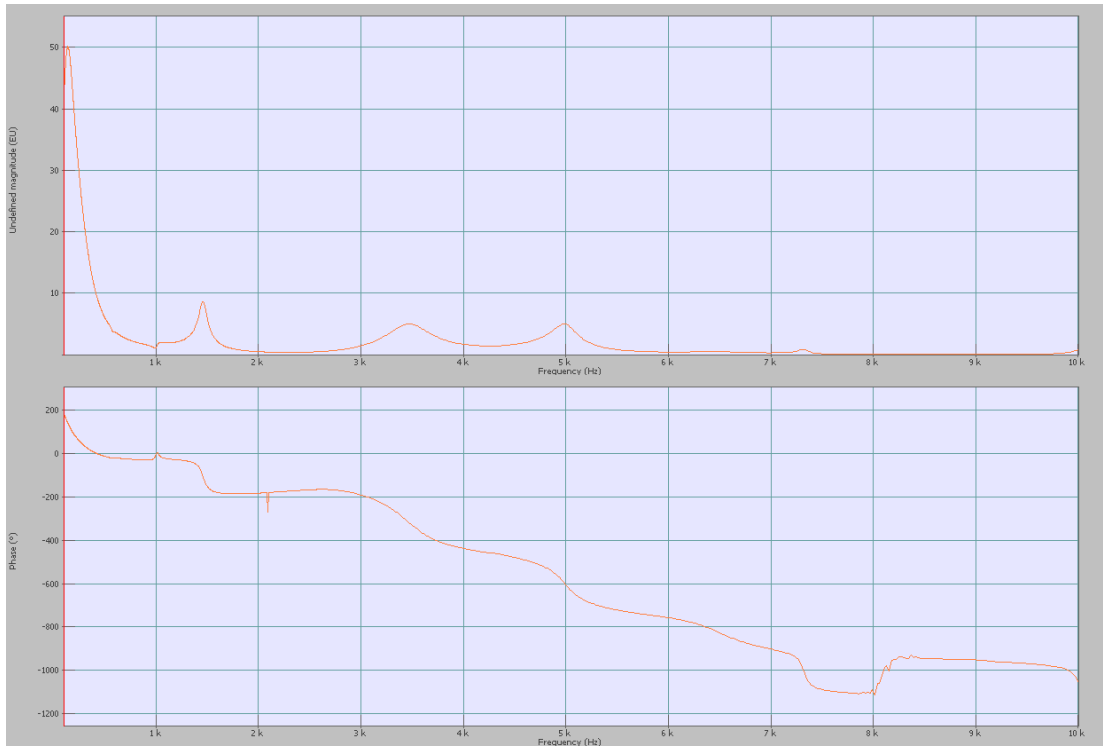

➤ Real/Imaginary

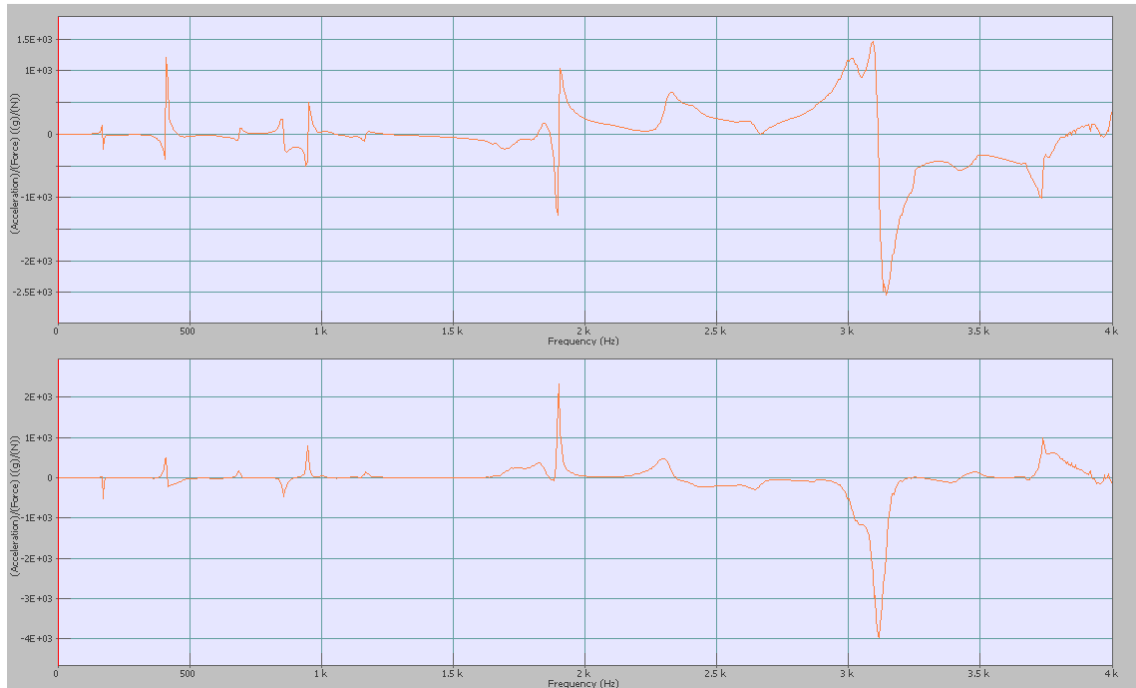

➤ Polar

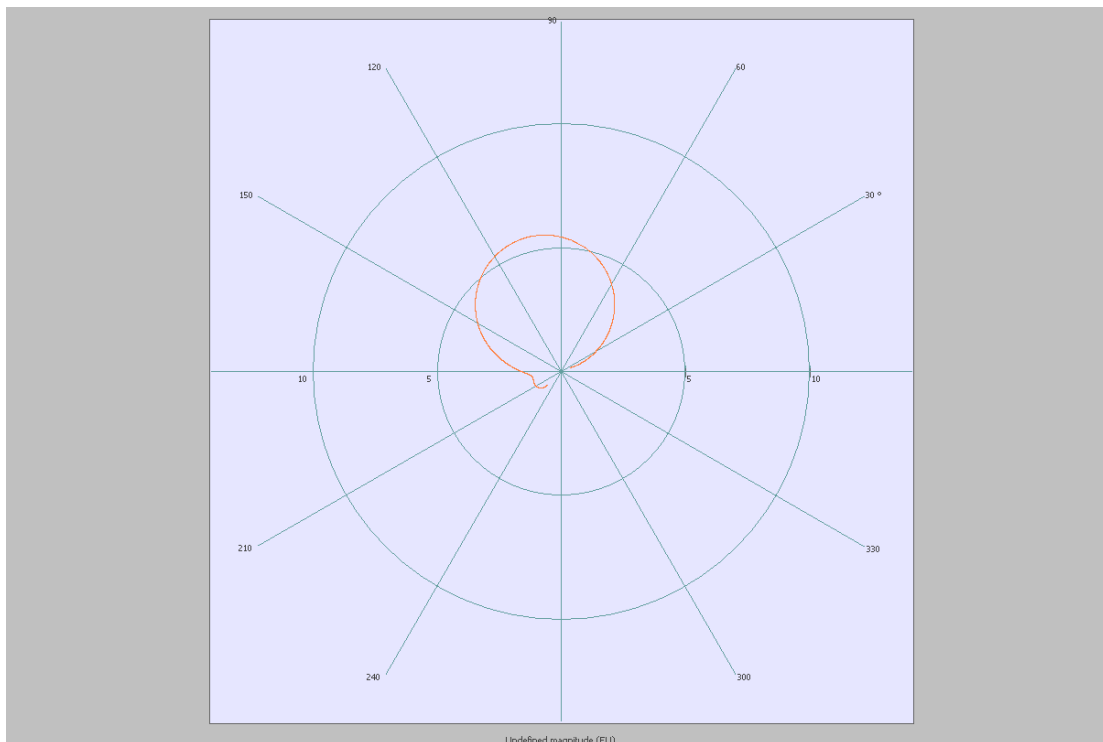

➤ Phase/Magnitude

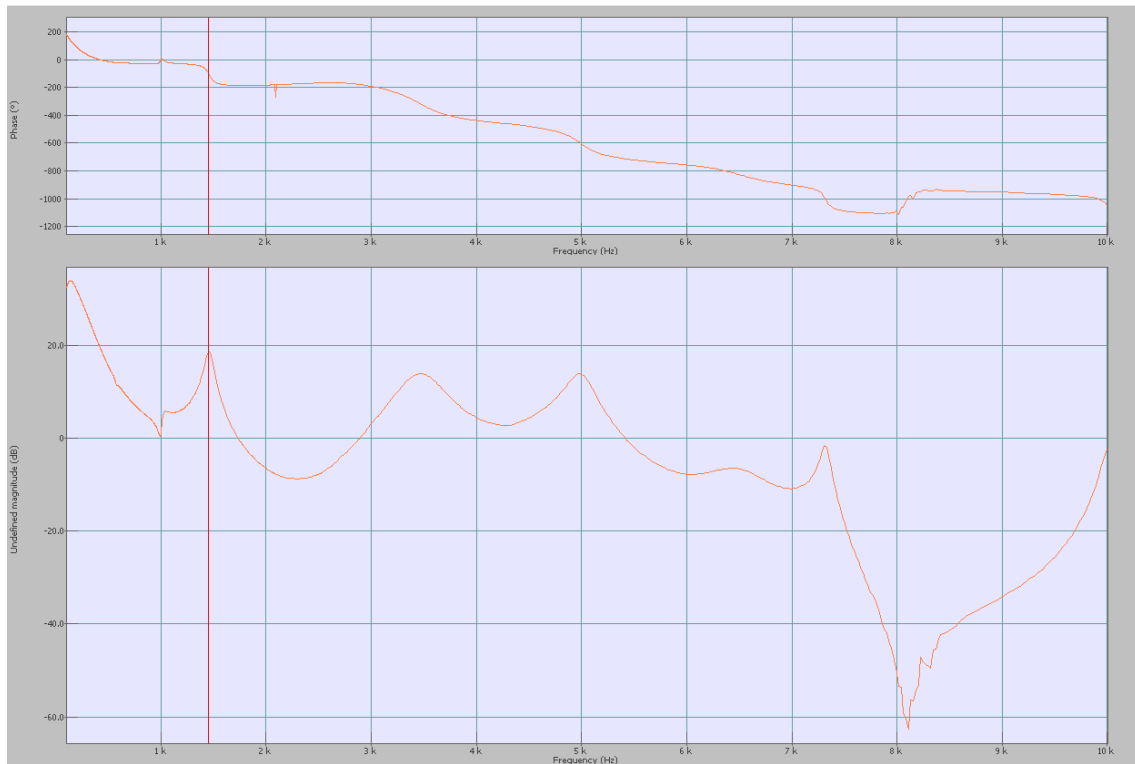

➤ Merged Module/Phase

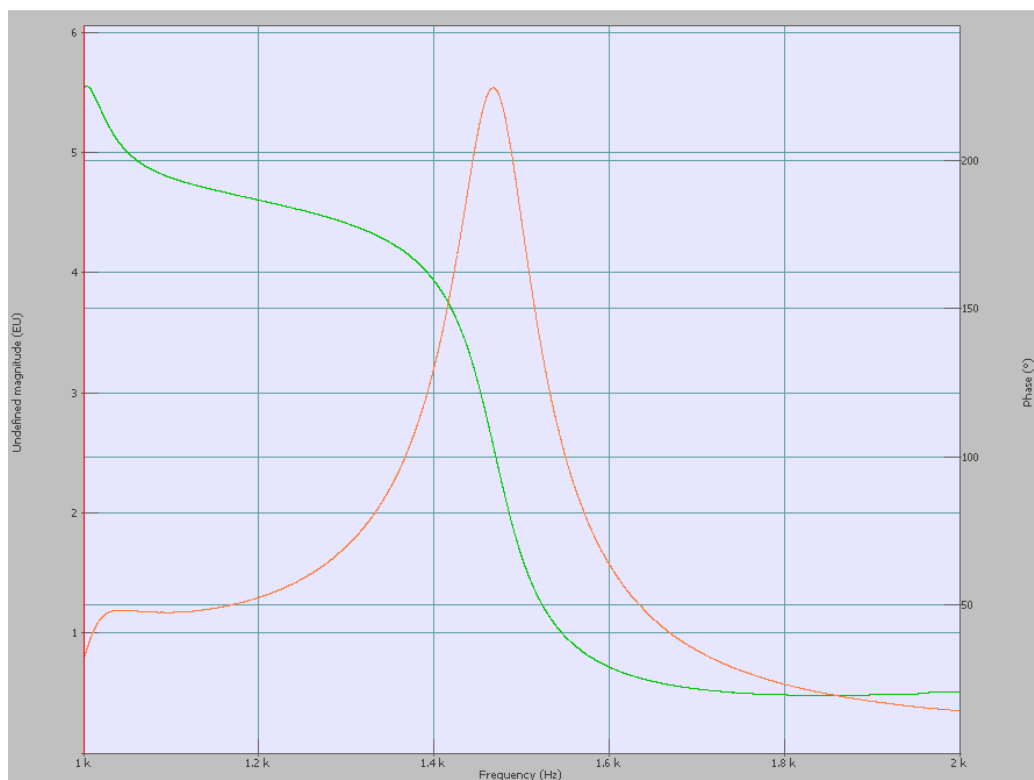

COHERENCE



MEASUREMENT REFERENCE LEVEL

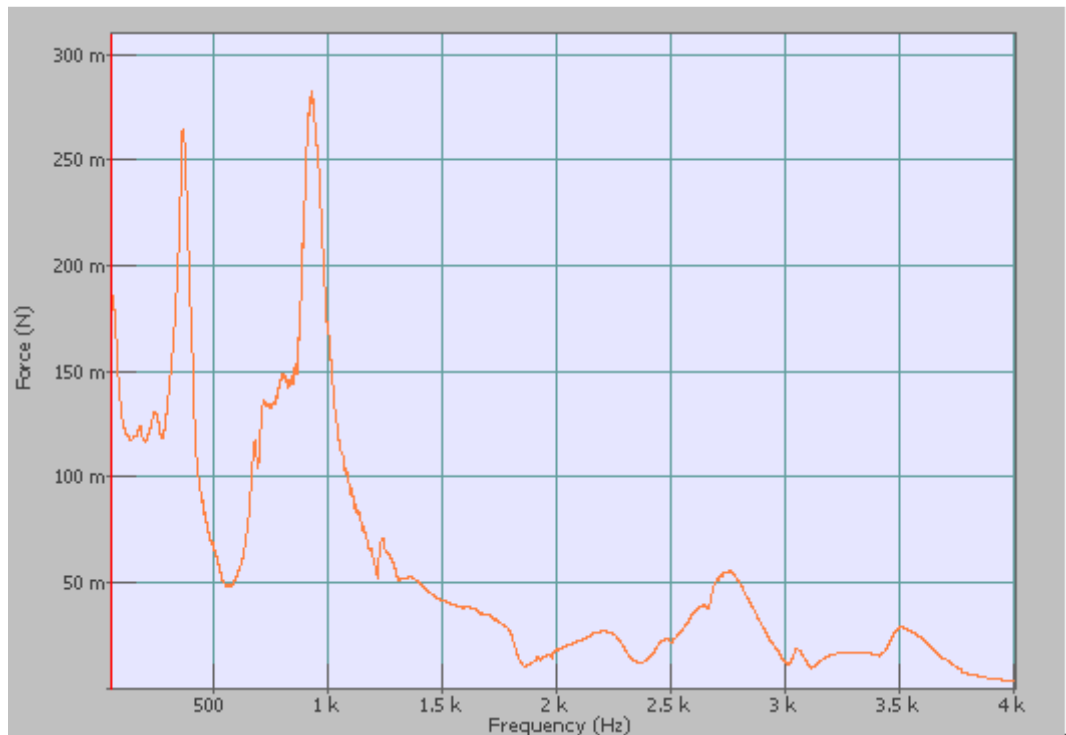

MEASUREMENT RESPONSE LEVEL

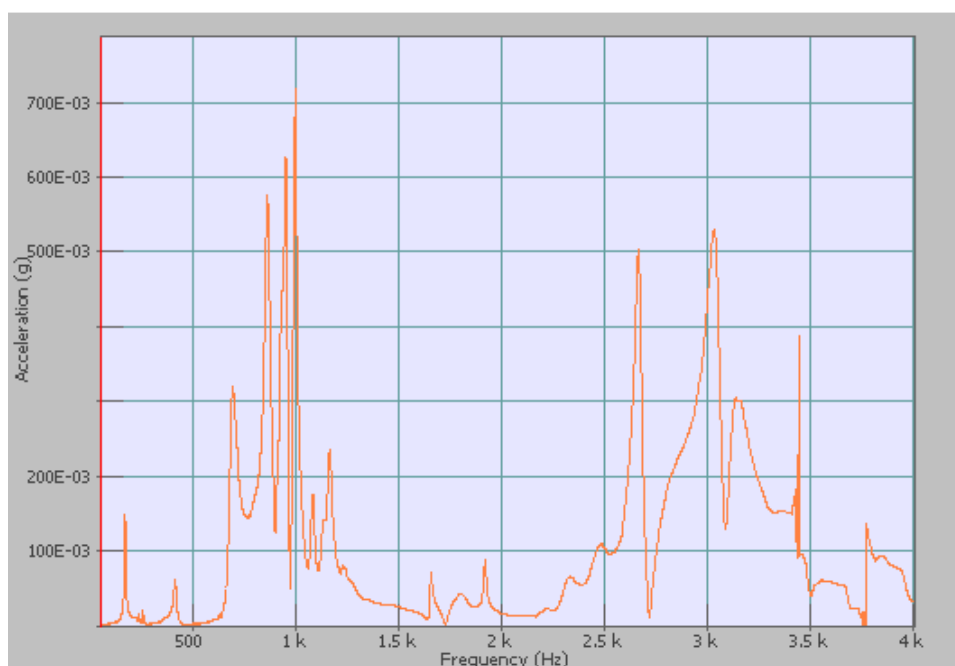

Note: for all these type of graphs, all settings for the graph available in NVGate are also available with Advanced Swept Sine by right clicking on the graph or graph window.

EDIT MENU

EDIT SETTINGS

This menu is to edit settings of the Advanced Swept Sine measurement (see below for more information about each setting). Settings are not available for modification during a measurement.

EDIT INPUT

This displays the following window:

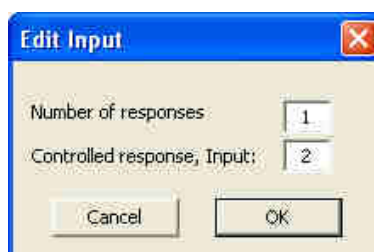

It is possible to select the number of response (depending of the hardware connected, that means this number of responses could be between 1 and 31).

The next setting is the number of the input the user wants to control. Note that the input 1 is not available because it is automatically the reference input.

By clicking on 'OK', the inputs properties will be displayed.

EDITING AND SAVING SETTINGS

Editing settings is available through menu "Edit" >> "Edit Settings"

This command opens a new window displaying General Settings, applicable for all spans, in the upper part and Span Settings, specific for each span, in the lower part. :

General Settings	
Span count (1 to 8)	1
Lowest frequency (0.01 Hz to 40 kHz, step 0.001 Hz)	10.000
Highest frequency (0.01 Hz to 40 kHz, step 0.001 Hz)	10000.000
Level tolerance (1-100 %, step 1)	10
Max tries (1 to 100)	3
RMS output level limit (0.01 to 7 V, step 1 mV)	7.000
Level limiting	Off
RMS reference level limit (Up to 10.000000 V)	1.000000
RMS response level limit (Up to 10.000000 V)	1.000000
Direction	Up
Span Settings:	
	Span 1
Low frequency (Hz)	10.000
High frequency (Hz)	10000.000
Sweep type (Lin or Log)	Lin
Frequency point number (1 to 10000 step 1)	10
Active	Yes
Excitation mode	Fixed
Low frequency target level	1.000000
High frequency target level	1.000000
Level control mode	Without
Generator frequency transition speed (Hz/s)	400.000
Minimum stabilization time (in s)	0.000
Minimum stabilization (in sine generator period)	0
Minimum measurement averaging time (in s)	0.030
Minimum measurement averaging (in sine generator period)	10
Boosted sweep mode	No
Booster module threshold (0.01 to 10 dB step 0.001 dB)	1.000
Booster phase threshold (0.1 to 180 ° step 0.1 °)	10.000

GENERAL SETTINGS

The General Settings apply for all spans.

Span Count (from 1 to 8):

A complete measurement can be split into 1 to 8 separate frequency spans; this multi-span capability is useful, for example, to define different frequency step sizes on the whole frequency range or to adjust excitation level for different frequency ranges. The high frequency of a span always corresponds to the low frequency of the next span.

Lowest and Highest Frequency (from 10 mHz to 40 kHz, resolution 1 mHz):

These settings define the whole frequency range of the measurement. Frequency range can start as low as 0.01 Hz and go up to 40 kHz. Frequency input resolution is 0.001Hz.

Level tolerance (1 to 100%, resolution 1%):

This setting defines the allowed tolerance between the target level and the measured level, which validates one frequency measurement point.

Note: the level limiting function (if enabled) has always priority on level tolerance.

Max tries (from 1 to 100):

This setting defines for a frequency measurement point the maximum number of tries in order to reach target level or to be conformant with level limits.

Tips: We recommend to set this value at least at 3 in order to process measurements with either reference or response level control or active level limiting.

RMS output level limit (from 0.01 to 7 V, resolution 1 mV):

This setting fixes the absolute limit for the output level during the measurement. The maximum value of this setting is 7.07 V RMS corresponding to ± 10 V peak on generator output (this value is also the default value).

Note: this limitation is active in any case and has the higher priority on other level control functionalities. In any case generator output level will never exceed this value.

Level limiting:

Level limiting function can also optionally be activated (ON) in order to guarantee that predefined levels are not exceeded at reference and/or response channel. If any measured level at reference or response channel is higher than its corresponding limit, the generator amplitude is decreased accordingly and a new measurement is processed.

Note: this function cannot guarantee that a level greater than user-defined limit will never appear. It guarantees that a transfer function point measurement is validated only if the measured level is below this limit.

Tips: this function is very useful when user wants to avoid a too large response level (with perhaps non linearity) due to a resonance when using constant excitation (and/or reference) level.

RMS reference level limit:

This setting defines maximum limit for reference level in order to validate a frequency point measurement. Active only if <Level limiting> is ON.

RMS response level limit:

This setting defines maximum limit for response level in order to validate a frequency point measurement. Active only if <Level limiting> is ON.

Note: In case the user want to use the level limiting only on reference (or on response), the level limit of the response (or of the reference) must be set to the maximum value.

Direction:

This setting defines if measurements are at measurement time processed from lowest to highest frequency (UP) or from the highest to lowest frequency (DOWN) In that last case, the measurement are processed in descending order of spans (from higher number to lower one).

SPAN SETTINGS

For each measurement span the following settings are defined:

Low and High frequency:

The ratio between high and low frequencies in a span must be greater than 1.0 and up to 10000. Frequency values can be lower than 0.01 Hz and up to 40 kHz with a resolution as low as 0.001 Hz.

Note: Only <High frequency> of each span (except the highest one) can be adjusted; modifying this frequency automatically adjusts <Low frequency> of next span to the same value. Low frequency of first span and high frequency of last span are set by general settings <Lowest and Highest Frequency>

Sweep type:

This setting specifies if the frequency steps for the span will increase in a logarithmic (ratio between 2 consecutive frequencies is constant as in a geometric progression) or linear fashion (difference between 2 consecutive frequencies is constant as in an arithmetic progression).

This setting defines the step between to measurement. The Log sweep gives more points in low frequency, and less point in high frequency, compared to Lin sweep. It is useful for giving a plot in which attenuation or gain of n dB/octave appears as a line.

Frequency point number (from 1 to 10 000):

This setting specifies the number in the span of measurement frequency points for transfer function. The real number of measurements can be higher as we can have adjustments for excitation level control and/or lower if BOOSTED mode is used.

Note: Large values produce higher frequency resolution at the cost of longer acquisition time. Boosted mode can be used to reduce measurement time.

Tips: Number of frequency point includes low and high frequency points. So, for example, to get frequency points from 200 Hz up to 800 Hz with 100 Hz linear spacing <Frequency point number> must be set to 7.

Active:

This setting let you the opportunity to skip the span during measurement. If set to NO the Advanced Swept Sine smoothly stops the generator at processing end of previous span and goes to process next active span starting smoothly the generator.

Tips: this capability can be used, for example, to redo transfer function measurements on a specific frequency range of interest.

Excitation mode:

For a measurement span the target excitation level can be set to a:

- Fixed level for whole span
- Variable with frequency during the span.

In this last mode, variation law with frequency between these 2 values is the same as defined in <Sweep Type>:

- Logarithmic, the target level versus frequency curve appears a straight line on a log/log display.
- Linear, the target level versus frequency curve appears a straight line on a lin/lin display.

Target levels are set by user in physical units (also called Engineering Units, EU). Physical unit depends of the selected control mode (see below).

Low frequency target level:

This setting defines the target level value in <Fixed> excitation mode and level for low frequency in <Variable> excitation mode

High frequency target level:

This setting defines the target level value in <Variable> excitation mode for high frequency.

Level control mode:

The excitation level can be controlled in 3 different modes:

- Without: amplitude of generator is set with no additional control to target level value at each frequency step (target level is in Volt, V).
- On reference: amplitude of generator is adjusted in order to get target value at the reference input (Physical unit of reference input is used for excitation level settings).
- On response: amplitude of generator is adjusted in order to get target value at the measurement input (Physical unit of measurement input is used for excitation level settings).

Note: Adjustment is applied if measured value at selected input is out of the bounds defined by the "Amplitude tolerance" global setting. In that case output generator amplitude is modified and a new step measurement is triggered at the same frequency. This adjustment is repeated if necessary; <Max tries> general setting limits repetition.

Note: Adjustment takes also into account <level limiting> if active.

Note: On 'reference' or on 'response' mode, for the first measurement generator Advanced swept sine has no information on actuator and/or system response to compute needed generator output level from user defined target level. So a first measurement is done with generator output level set to 1/100th of RMS output level limit and using measured levels, a new generator level is computed for next try in order to reach target level.

Generator frequency transition speed:

When a measurement point is available and stored, the generator smoothly sweeps to next frequency point measurement with a transition speed defined by this setting.

Minimum stabilization time (in s) and (in sine generator period):

When generator has reached frequency and amplitude level targets, the swept sine analyzer waits a user-defined time in order to guarantee stabilization of system under measurement. This time is defined as a minimum fixed time and as minimum periods of sine generator.

Tips: Stabilization time defined in sine generator periods is efficient for spans with large variation of frequency as the whole time measurement is lower than using constant stabilization time based on lower frequency.

Minimum measurement averaging time (in s) and (in sine generator period):

These settings define the minimum averaging time for transfer function measurement after stabilization delay. A higher time gives better precision in case of noisy signals giving a low coherence.

The minimum measurement averaging time is 30 ms or 10 periods of generator, which is greater.

Boosted swept mode:

In order to speed up measurement with large number of points, Boosted mode skips over frequency measurement steps with small variations in the transfer function.

Boosted mode examines differences in amplitude and phase between the current measurement point and the previous one. If these differences are within the user-defined thresholds, the sweep will continue taking larger steps and so skipping measurement points.

If differences in amplitude and phase are greater than user defined thresholds, the number of skipped points is halved and the current frequency point is moved back and a new measurement is processed.

The transfer function of skipped frequency points is computed using interpolation between two real measurements whose differences are within defined threshold.

With this adjustable algorithm, the number of skipped points can vary between 2 and 16 giving large decreases in whole measurement time (dependent of transfer function).

Booster module and phase thresholds (from 0.01 to 10 dB with resolution of 0.001 dB for the module, and 0.1 to 180° with resolution of 0.1° for the phase):

These 2 settings are used in BOOSTED mode to define limits on amplitude and phase variations, which enable skipping points.

This Boosted mode with both module and phase threshold is a guarantee that no points would be lost and all resonance and phase change would be detected.

Example on how works the boosted mode:

- The measurement start at point 1. Then point 2 is measured.
- If the difference (in term of amplitude and phase) between values of point 1 and 2 is under the user-defined threshold, the next measurement point would be point 4. In other case it will be point 3.
- Point 4 is measured, if the difference between values of point 2 and 4 is under the user-defined threshold, the next measurement point would be point 8 and point 3 is interpolated. In other case the measurement go back and point 3 is measured.
- Point 8 is measured, if the difference between values of point 4 and 8 is under the user-defined threshold, the next measurement point would be point 16 and points 5, 6 and 7 are interpolated. In other case the measurement go back and point 6 is measured and if the difference between point 4 and point 6 is under the user-defined threshold, next measurement point would be 8 (the previous step is still available), if not point 5 is calculated then measurement go to point 7.
- Point 16 is measured, the same comparison is made to know if next point is 32 or if some points between 8 and 16 need to be calculated.
- ...

Note: in any case no point would be measured twice, that means that it is really an optimization in term of time measurement without any risks of losing points.

Details on measured or interpolated points are available in the log file. Note that the interpolated points have no FFT settings associated (the corresponding settings are set to "0" in the log file).

NVGATE SETTINGS

Some settings on inputs can be modified using NVGATE. Advanced swept sine configures automatically NVGATE control panel with 3 tabs, the first for the reference input, the second one for the response input and the last one for general settings.

The following settings are the default setting automatically displayed in NVGate when starting Advanced Swept Sine.

- Inputs 1 and 2 are connected on Channels 1 and 2 of the FFT plug-in.
- Cross-Spectre channel 2/channel 1 authorized.
- Weighting windows: Hanning
- Advanced sine 1 on output 1 is enabled:
 - Mode = Pure Tone
 - Synchro = Free run
 - Peak Level = 0 V
 - Freq = 0 Hz
 - Mute = On
 - Stabilization time = 0 (time delays are managed in the FFT plug-in)
 - Amplitude variation = 1s
 - Phase speed = 30 ms Rad/s
 - Gain = 0
 - Phase offset = 0
 - Output 1 transition time = 10 ms

These settings ensure that there is no output signal from NVGate, in order to protect any output connected through NVGate (for example a shaker).

- Saving option: set to 'Do not save', in order not to save each point of the Advanced Swept sine measurement.

- In the FFT plug-in:
 - Average type: Linear
 - Trigger: Pure Tone stabilized
 - Overlap = 75%
 - Number of lines: 401 lines
 - Zoom factor: none (i.e. zoom set on off)

In the control Panel 3 tabs have been added with several settings of NVGate.

- Reference and Response: Input 1 is called 'Reference' and Input N (N is the number of the input selected by the user) 'Response' and this two tabs displayed settings of these inputs. Between brackets is displayed the number of the input corresponding.

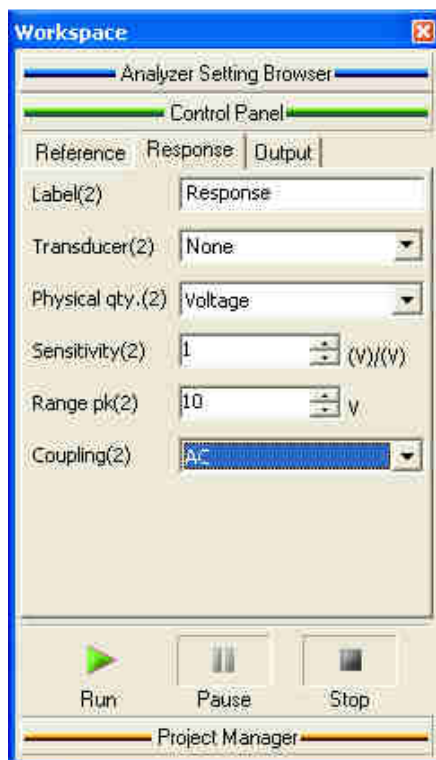

- General settings:
 - Level variation: this setting in second represents the transition time from a level to another level.
 - Current frequency: this status is the current frequency of the generator output.
 - Status: this indicates if the generator is 'running up' (i.e. the generator is waiting to reach the level) or 'sweeping' (i.e. the generator is in service).

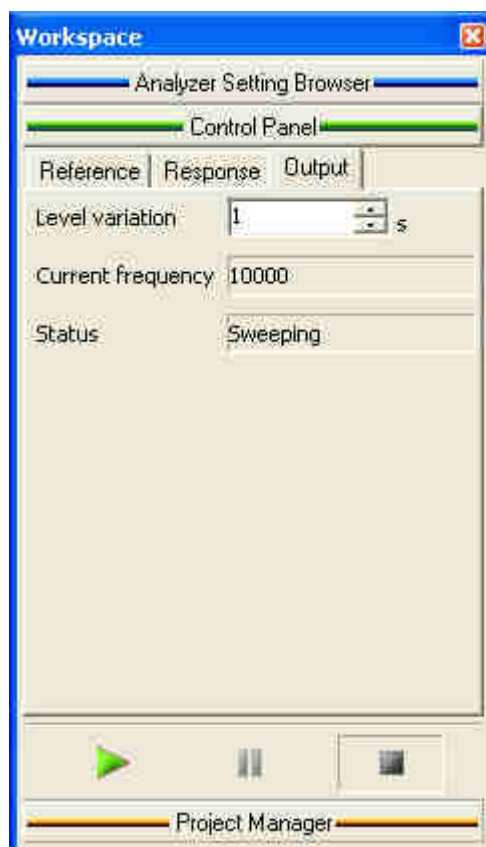

SAVING SETTINGS

Settings of Advanced Swept sine measurement are save through Advanced Swept sine, using **Save** or **Save as** from the **File** menu.

Settings are saved with the extension .sws.

Note: When the settings are saved in a file “file_name.sws”, if the current project in NVGate is the default project the project would be automatically renamed as “SWS_file_name”.

MEASUREMENT STORAGE

SAVING RESULTS IN NVGATE

As for any NVGate project you can save the results using the 'save result' menu.

LOG FILE DESCRIPTION

A new log file is written automatically at each new measurement, this log file has the same name than the settings file (.sws) used or 'default'. The previous log file will be renamed with the same name with the extension "_old" in order to compare two successive measurements (not more, to compare more measurements the user must rename .los files). This file includes all information on each step measurement in text format (can be imported into EXCEL). This file is located in corresponding 'OROS Advanced Swept Sine' directory, that is to say in the "LOG" file of installation, and the extension is .los.

Tip: there is a shortcut in menu 'Start' then 'All programs' called 'OROS Advanced Swept Sine' then 'Advanced Swept Sine Log Files'.

MEASUREMENT EXAMPLES

MODAL MEASUREMENT

This example is based on a shaker measurement. The aim of this measurement is to define a specific mode of vibration of the structure (resonant frequencies, deflection shape...)

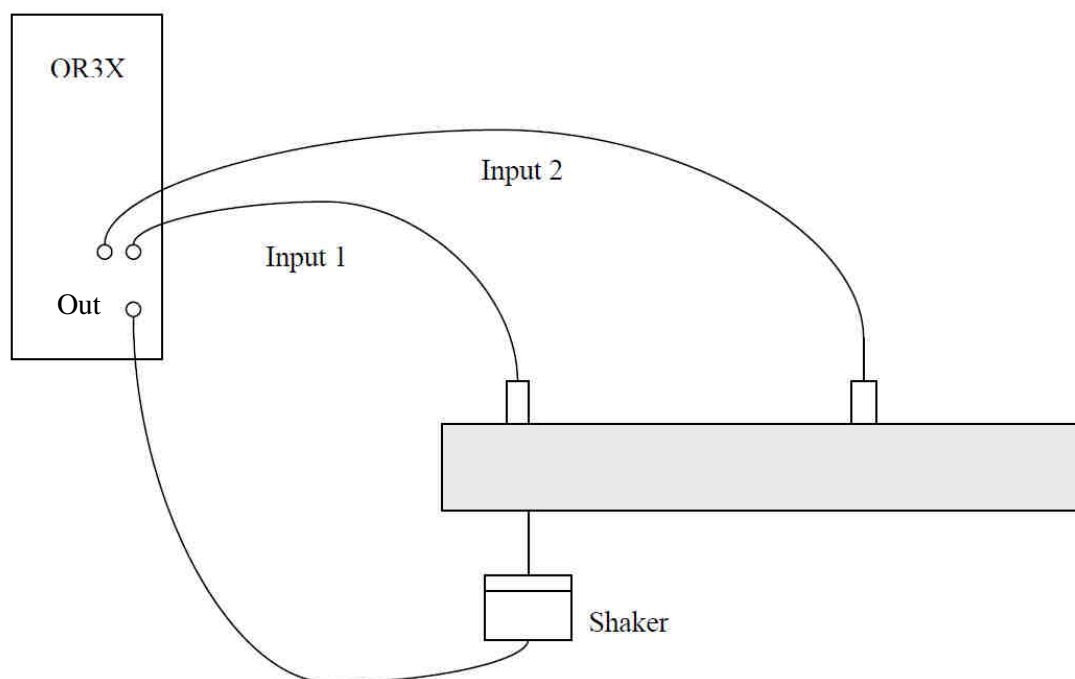

Input 1 is the reference (force sensor) and Input 2 is the response (accelerometer). The shaker is on an output. The Advanced Swept Sine displays Function transfer (magnitude and phase) in order to determine resonance and phase change.

A first measurement has been made without boosted mode (orange trace)

Time of measurement (extract from the log file):

1600 measured points - 0 interpolated points

End Time:06/23/05 16:45:10

Duration: 00:24:19

Termination: Normal

Next measurement has been done with the boosted mode active (to optimize time measurement) in exactly the same situation (green trace)

Boosted module threshold of 5 dB and boosted phase threshold of 10°.

Time measurement (extract from the log file):

532 measured points - 1068 interpolated points

End Time:06/23/05 16:03:49

Duration: 00:07:53

Termination: Normal

No visible difference in the coherence function

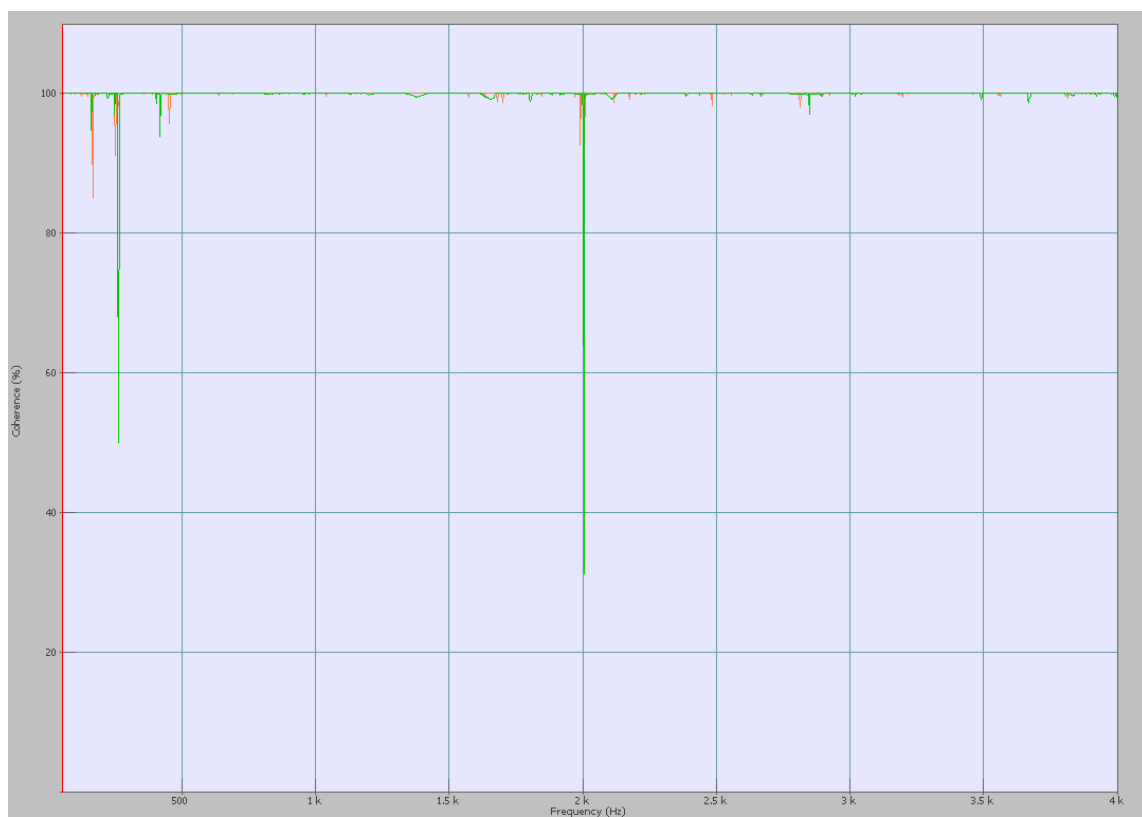

The transfer function is displayed on the same graph for both measurements in order to compare the accuracy.

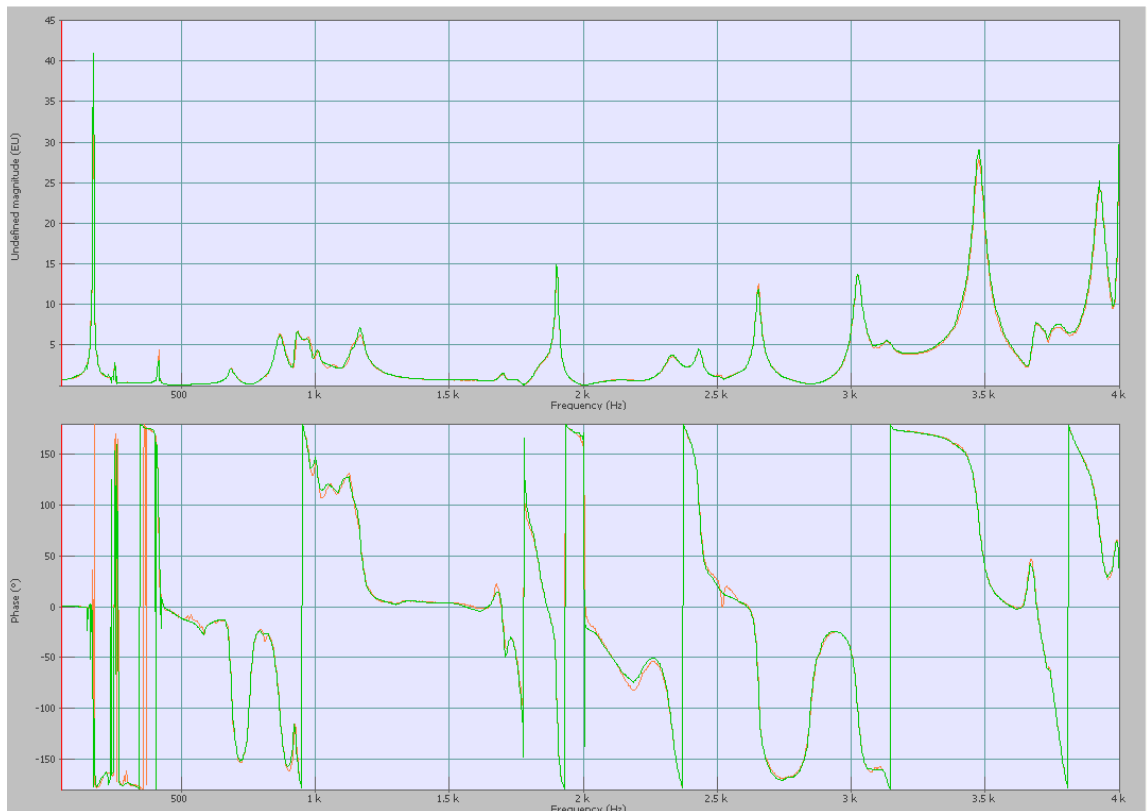

The displayed result shows that the accuracy of the measurement is as good as without the boosted mode. The phase and module graphs are similar than for the previous measurement. No points are missing and the interpolation of some points is really closed to the measurement itself.

After it is possible to focus on a specific frequency bandwidth to determine a resonant frequency:

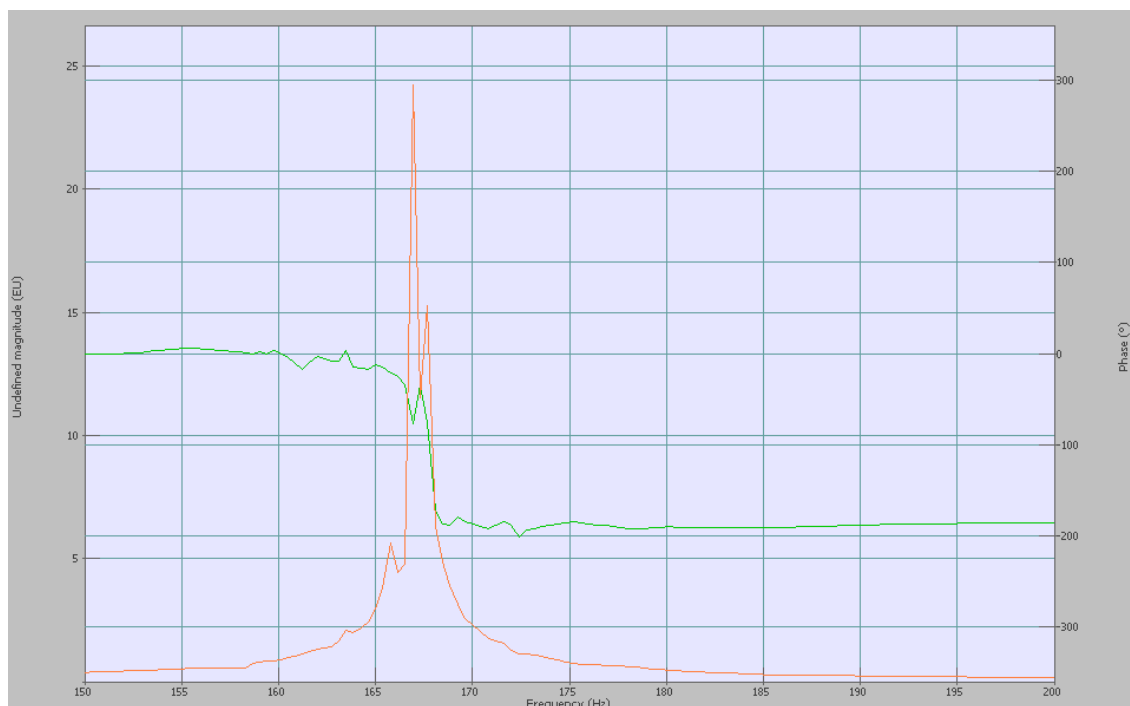

ACOUSTIC MEASUREMENT

This example is based on a muffler; the aim of this measurement is to define resonance and anti-resonance in order to determine resonance and frequencies absorbed by the muffler.

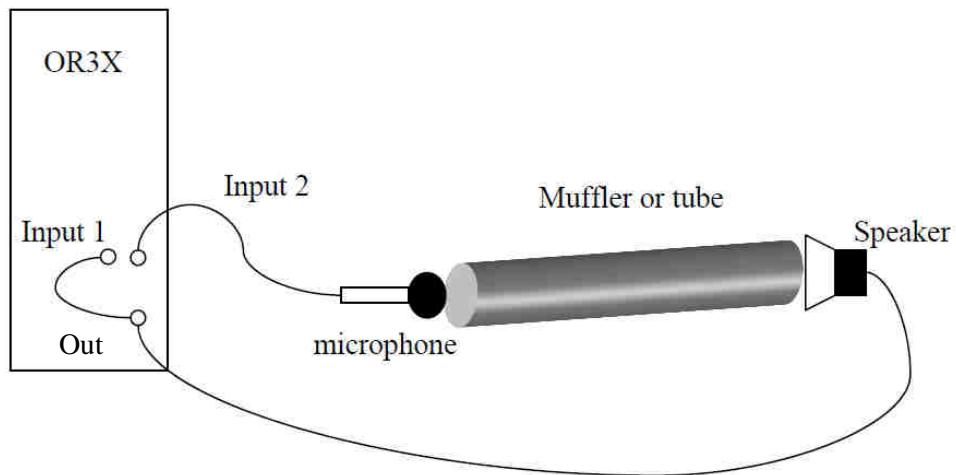

First measurement is an overview on the bandwidth 100 Hz to 10 kHz in order to determine resonances and anti-resonances.

The coherence and the transfer function have been displayed

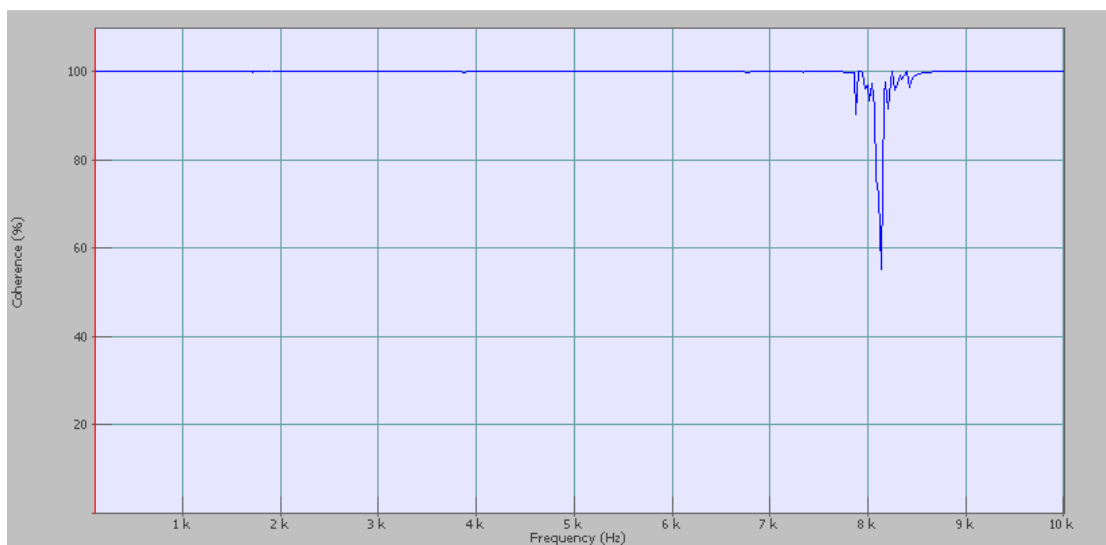

The coherence drop defines an anti-resonance around 8 kHz.

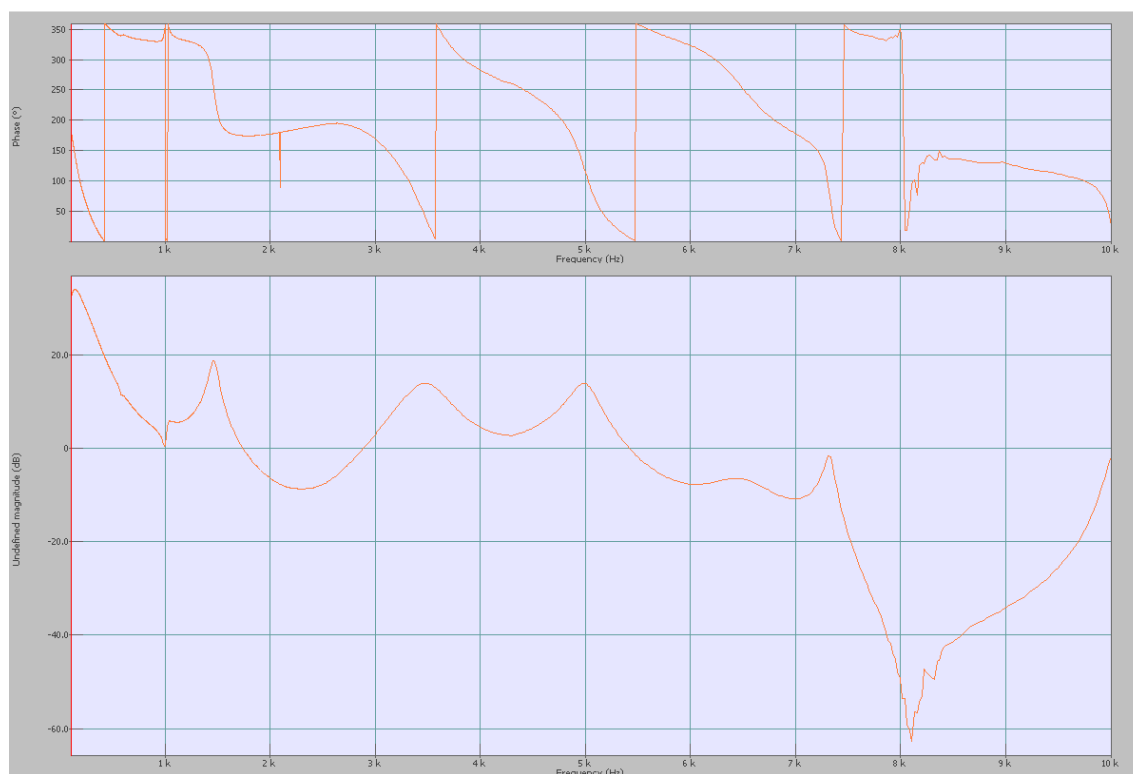

We can notice a resonance around 1.5 kHz.

In order to visualize properly these two phenomena, we use a multi-spans measurement with more points around interesting frequencies.

The measurement is split in 4 spans:

- 100 Hz to 1 kHz (non active)
- 1 kHz to 2 kHz (active)
- 2 kHz to 7 kHz (non active)
- 7 kHz to 10 kHz (active)

Spans where nothing interesting occurs are not activated in order to decrease time measurement.

Following results correspond to these settings.

The transfer function is displayed in Magnitude/Phase:

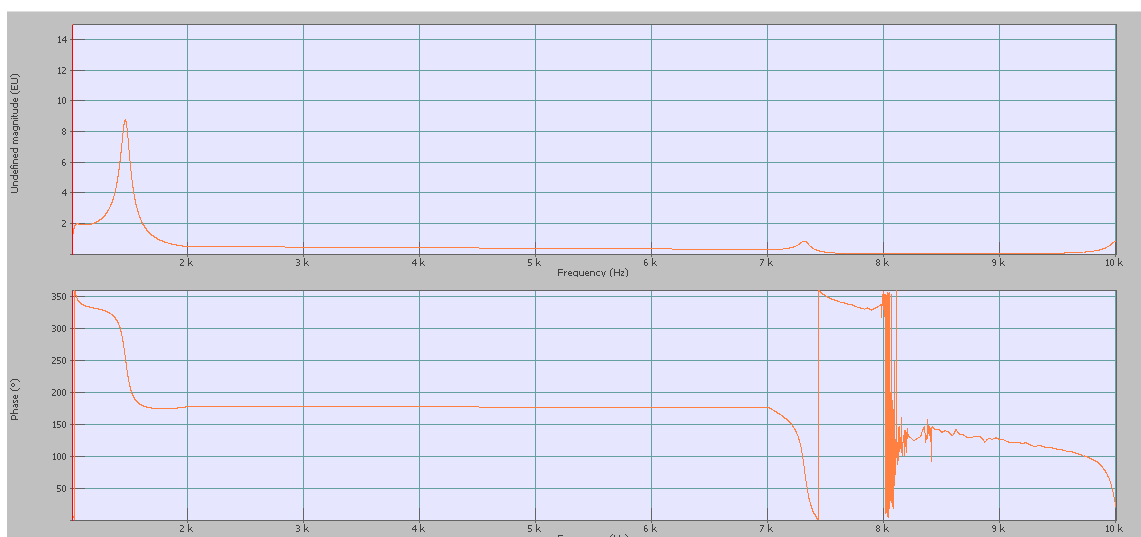

The change of phase is significant around the resonance (i.e. around 1.5 kHz) and at this frequency we can notice the magnitude of the transfer function.

For the anti-resonance it must be around 8 kHz, and this is confirmed on the coherence graph below with a significant coherence drop.

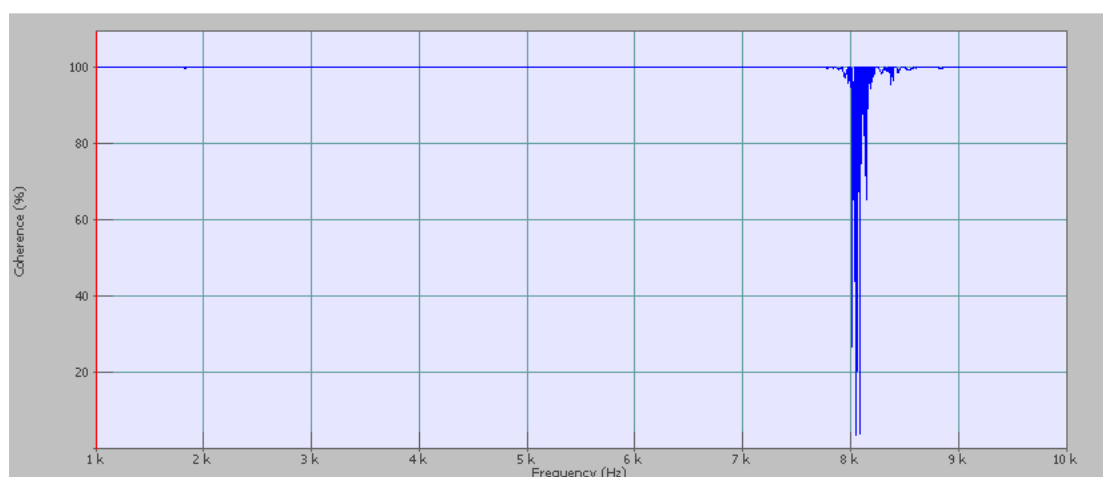

Then to see specific results on each phenomenon, two measurements have been done: one on the resonance (between 1 kHz and 2 kHz with 6 000 points) and another one on the anti-resonance (between 7 kHz and 10 kHz with 4 000 points). This could be done during the same measurement using the multi-span defined on each interesting zone. With a zoom through NVGate the following graphs could be displayed:

- Resonance (between 1 kHz and 2 kHz):

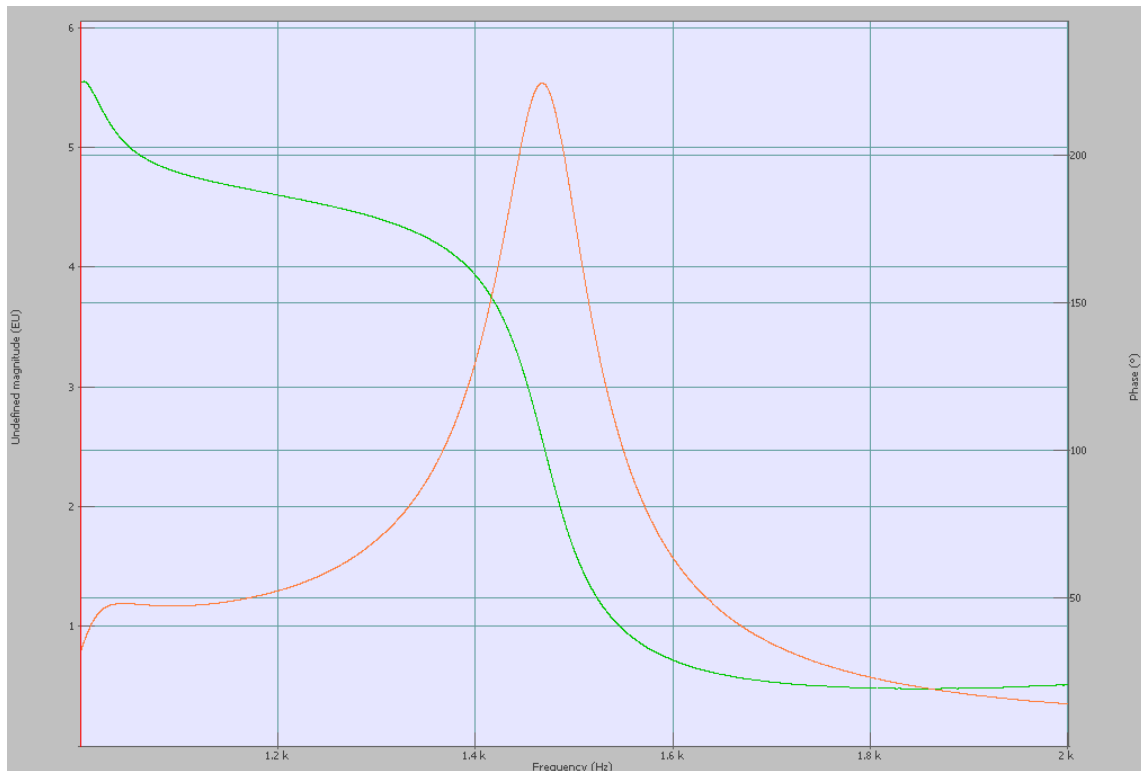

We can clearly see the resonance with the change of phase on a 'Merged Magnitude/Phase' graph.

- Anti-resonance (span between 7 kHz and 10 kHz):

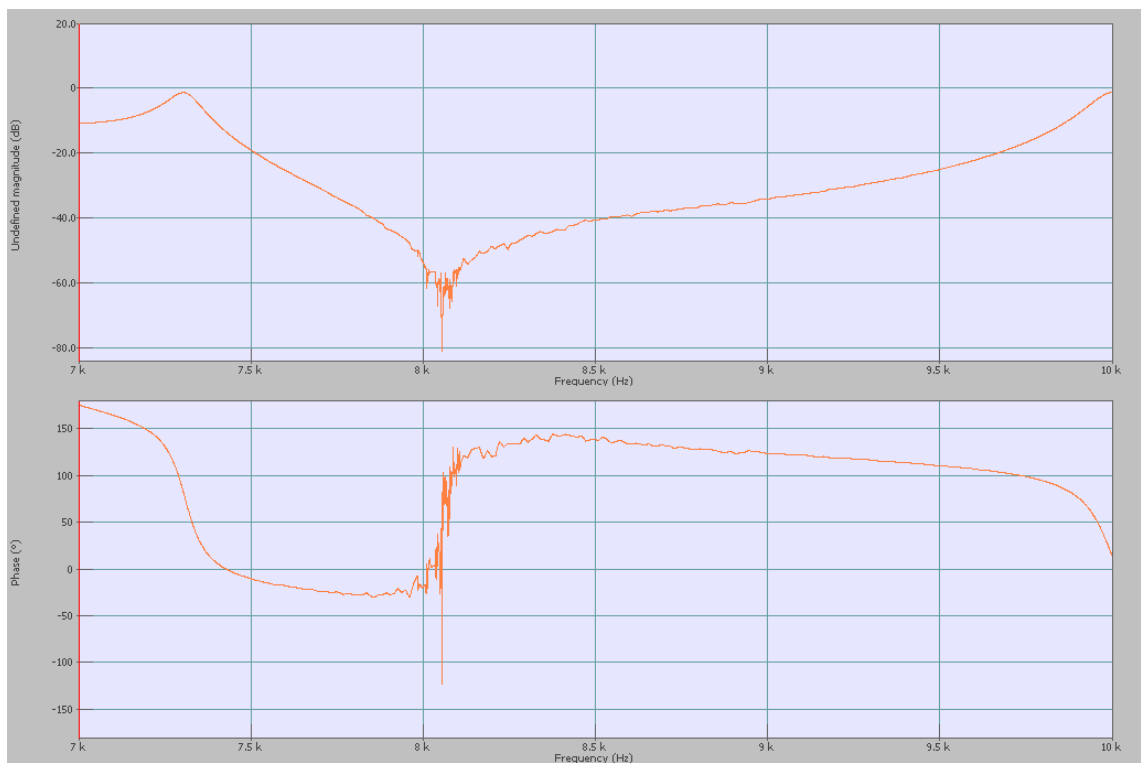

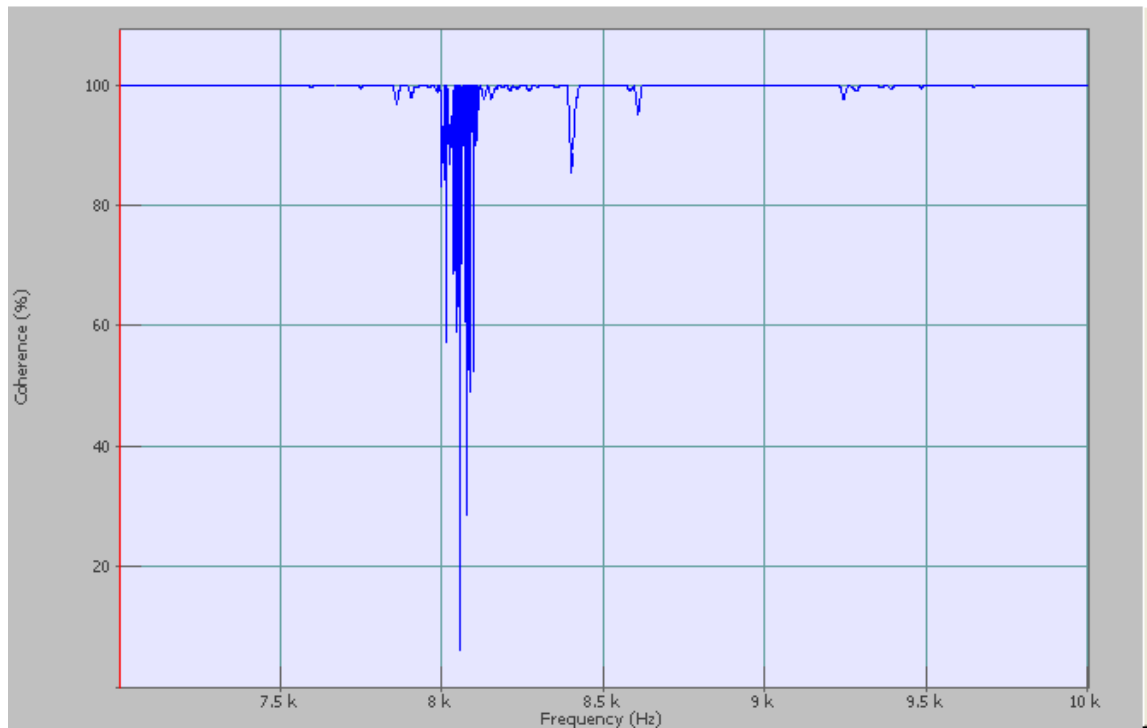

On this part we can see the anti-resonance on both graphs in order to determine the frequency absorbed by the muffler.

Note: these two examples are quite basic, but it is also possible to control the level on the response and/or on the reference with the level limiting of the Advanced Swept Sine solution.

SPECIFICATIONS

Frequency range	0.01 Hz to 40kHz
Frequency resolution	0.00002Hz
Max number of points	80 000 points
RMS level output	10mV to 7V
Output level control	fixed, on response or on response
Sweeping type	lin or log
Sweeping mode	up, down
Sweeping speed controls	stabilization time, transition speed, averaging per point
Sweeping optimization	boosted mode
Results	spectra, FRF (magnitude & phase; real & imaginary), coherence, polar
Amplitude accuracy	0.017 dB
Phase accuracy	0.07°